

05

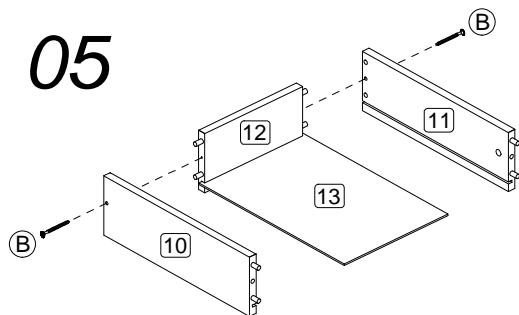

06

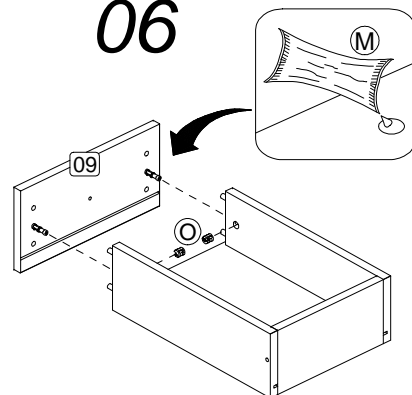

07

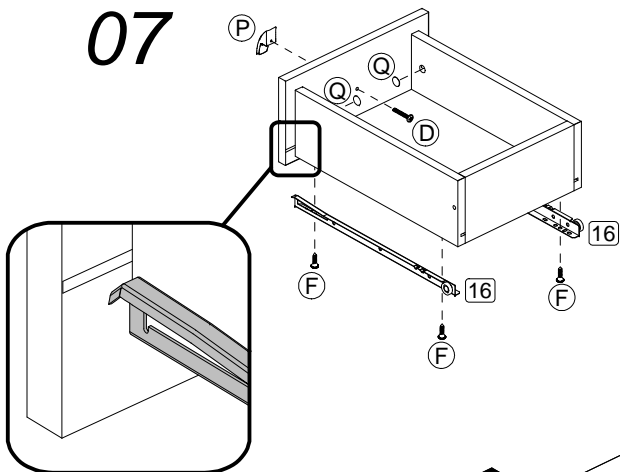

08

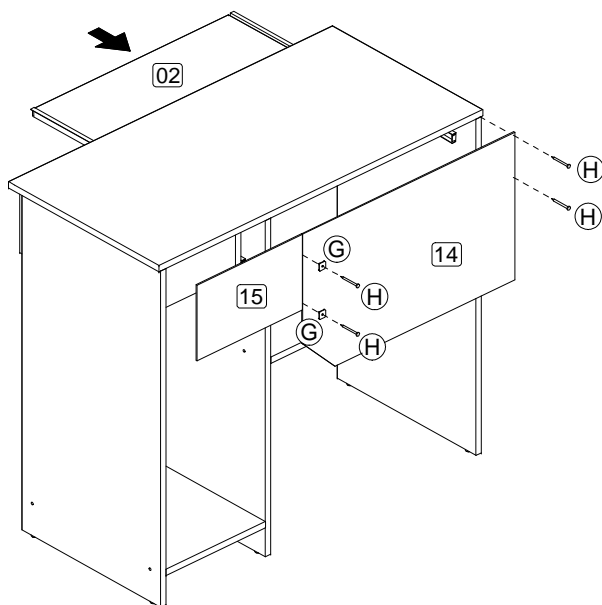

ATENÇÃO!!!
Utilize o giz de cera para dar acabamento nas arestas e correções de possíveis riscos nas peças.

ATENCIÓN!!!
Utilice el gis para los bordes y correcciones de posibles errores o daños en las piezas.

ATTENTION!!!
Use the crayons to finish edges and to fix possible damaged pieces.

INSTRUÇÕES DE MONTAGEM

INSTRUCTIVO DE ARMADO
ASSEMBLY INSTRUCTIONS



RSC 470 - km 203,3 BENTO GONÇALVES - RS - BRASIL
FONE: 54-3458.1300

sac@politorno.com.br
www.politorno.com.br

Escritinha Grajaú
Mesa de Computación Grajaú
Computer Desk Grajaú

Modelo
Modelo
Modelo

1213

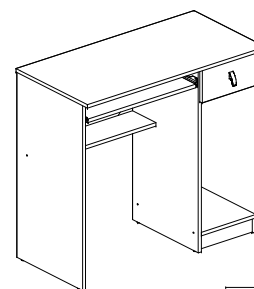

Caso você precise da indicação de um montador, consulte o site www.politorno.com.br. Temos profissionais capacitados para indicar nas principais cidades do Brasil.

KIT FERRAGEM
KIT HERRAJE
HARDWARE KIT

A		4,5x45	06
B		4,5x45	02
C			06
D		3,5x25	01
E		3,5x14	12
F		3,0x14	16
G			02
H		10x10	30
K			06
L		8x30	26
M			01
N			02
O			02
P			01
Q			02
R		Giz / Gis / Crayons	03

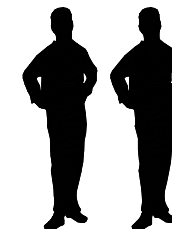

ANTES DE INICIAR A MONTAGEM, IDENTIFIQUE TODAS AS PEÇAS E ACESSÓRIOS.
 ANTES DE EMPEZAR EL ARMADO, IDENTIFIQUE TODAS LAS PIEZAS Y ACCESORIOS.
 BEFORE STARTING THE ASSEMBLY, IDENTIFY ALL PARTS AND ACCESSORIES.

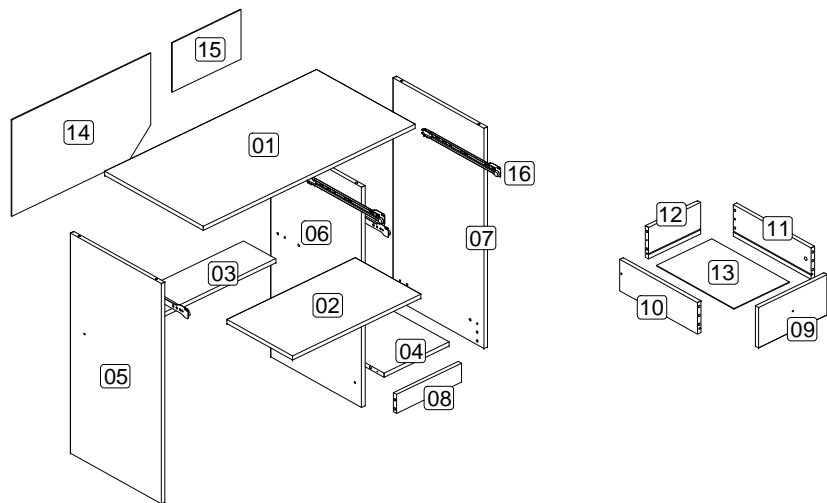

ETAPA DE PREPARAÇÃO DAS PEÇAS.
 FASE DE PREPARACIÓN DE LAS PIEZAS.
 STAGE OF PREPARATION OF THE PIECES.

01

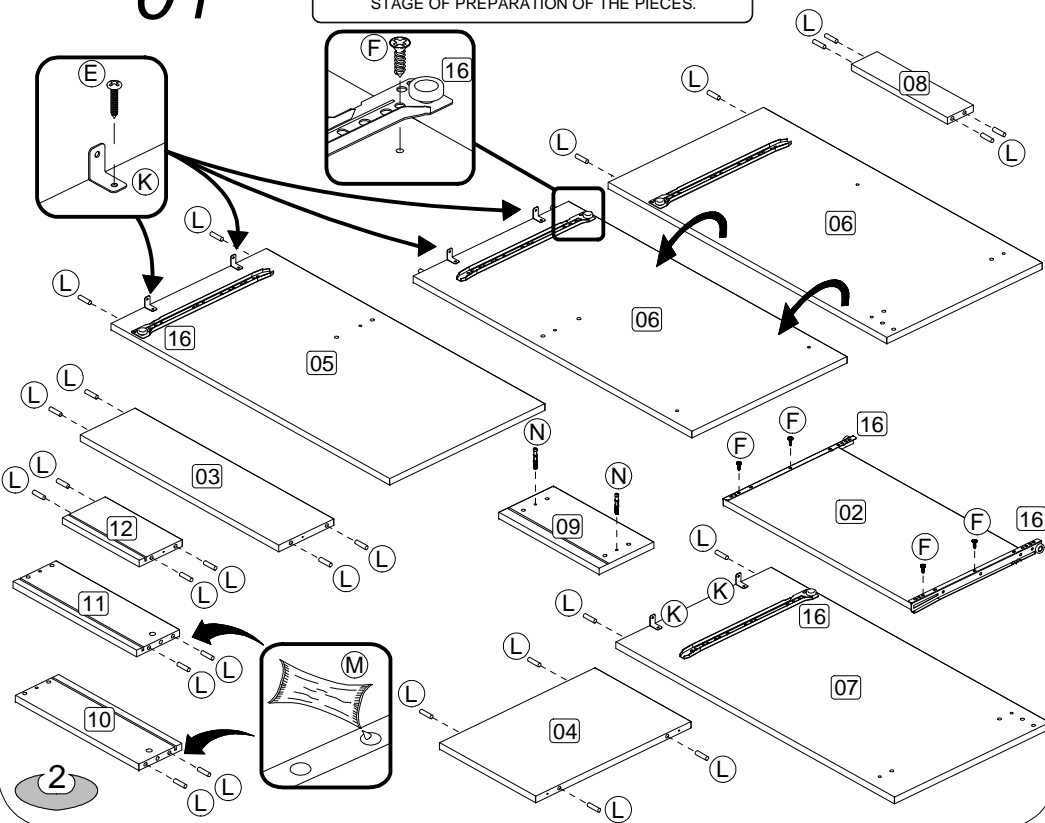

02

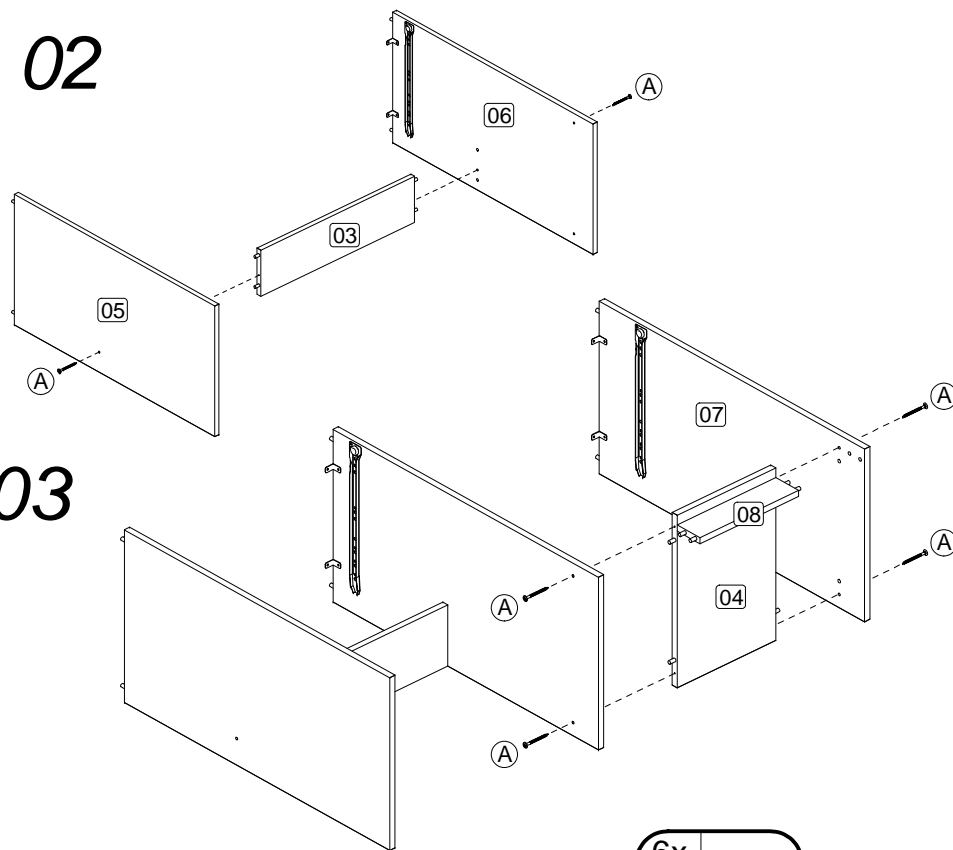

03

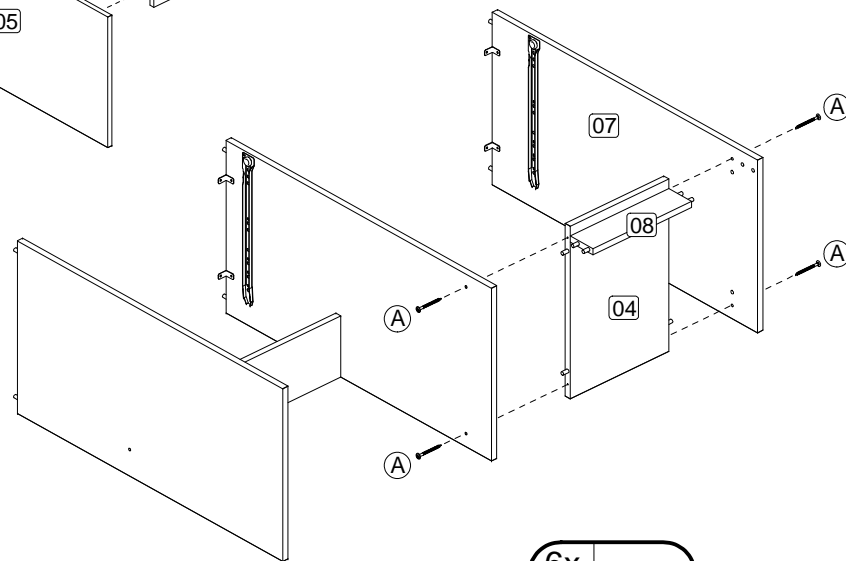

04

