

Dicas de Conservação / Maintenance Tips / Dicas para Conservación

*Para limpar ou tirar manchas, utilize uma flanela umedecida em solução de água e álcool, na mesma proporção. *Evite exposição ao sol.

**To clean or remove stains, use a piece of flannel dampened with a water and alcohol solution, in the same proportion. *Avoid direct sunlight.*

*Para limpar o sacar manchas, utilize uma flanela humedecida em solução de água e álcool, na mesma proporção. *Evite a exposição directa ao sol.

TERMO DE GARANTIA / RENUNCIA DE GARANTÍA / DISCLAIMER OF WARRANTY

Poliman Indústria e Comércio de Móveis Ltda., garante este produto (peças e mão de obra, por defeitos de fabricação), pelo prazo de seis meses a partir da data de emissão da nota fiscal de venda do produto ao consumidor.

La Poliman Indústria e Comércio de Móveis Ltda., garantiza que este producto (piezas y mano de obra por defectos de fabricación), por un período de seis meses a partir de la fecha de emisión de la factura de venta del producto al consumidor.

The Poliman Indústria e Comércio de Móveis Ltda., warrants this product (parts and labor for manufacturing defects), for a period of six months from the date of issuance of bill of sale of the product to the consumer.

DADOS INDISPENSÁVEIS PARA VALIDEZ DESTA GARANTIA. LOS DATOS ESENCIALES PARA LA VALIDEZ DE ESTA GARANTÍA. DATA ESSENTIAL FOR VALIDITY OF THIS GUARANTEE.

1) Apresentar este certificado de garantia acompanhado do recibo de compra do local de aquisição do produto.

1) Para presentar este certificado de garantia junto con el recibo de compra desde el lugar de compra.

1) To present this guarantee certificate together with the sales receipt from the place of purchase.

2) Esta garantia perderá sua validade mesmo dentro do prazo acima estipulado se:

2) This warranty will sustain valid even within the time stipulated above if:

2) Esta garantía será válida incluso sostener en el tiempo estipulado, si:

O produto apresentar danos por maus tratos, acidente, uso diferente do indicado ou uso em condições ambientais deficientes (contato direto com água, fogo, etc.);

El producto está dañado por el abuso, accidente, mal uso o uso diferente al indicado en las malas condiciones ambientales (contacto directo con agua, fuego, etc.);

The product is damaged by abuse, accident, misuse or use other than that indicated in poorenvironmental conditions (direct contact with water, fire, etc.).

Os vidros e espelhos quebrarem ou trincarem após a entrega e montagem dos produtos;

The windows and mirrors trincarem break or after the delivery and assembly of products;

Las ventanas y los espejos trincarem descanso o después de la entrega y montaje de productos;

Quando o produto não for montado por profissionais devidamente treinados pelo revendedor;

Cuando el producto no está instalado por profesionales capacitados por el concesionario;

When the product is not installed by professionals trained by the dealer;

Dobradiças, corrediças e puxadores somente terão sua garantia quando apresentarem defeitos de fabricação.

Bisagras, controles y deslizadores sólo tienen la garantía por defectos de fabricación.

Hinges, knobs and sliders only have your warranty if defective manufacturing.

3) Todo e qualquer produto com avarias deverá ser feito vistoria por parte do técnico autorizado pelo revendedor e indústria. Em hipótese alguma será realizada a troca total do produto.

3) Cualquier producto con daños debe ser realizado por la inspección técnica por el distribuidor autorizado y la industria.

En ningún caso se llevará a cabo el intercambio del producto.

3) Any product with damage should be done by the technical inspection by authorized dealer and industry.

In no event will be held the exchange of the product.

cozinha MUNIQUE

INSTRUÇÕES DE MONTAGEM
ASSEMBLING INSTRUCTIONS
INSTRUCCIONES DE MONTAJE

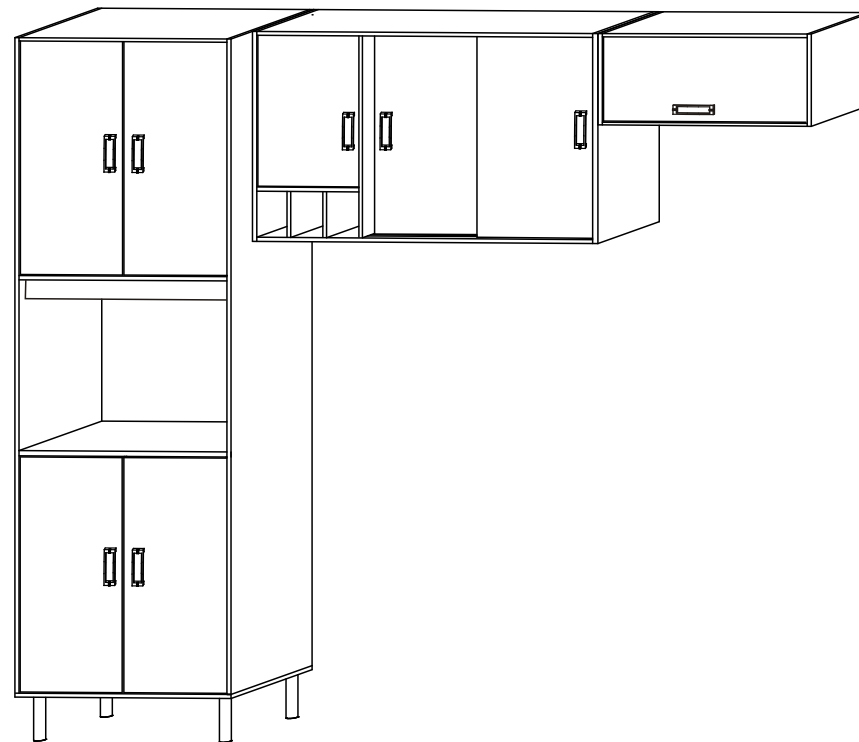

1060.2 - AMENDOA/ROVERE

1061.2 - ROVERE/AMENDOA

1071.2 - BRANCO/PRETO

1072.2 - CINZA/PRETO

Altura / Alto / Height - 2070mm





Profundidade / Profundidad / Depth - 390mm









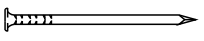
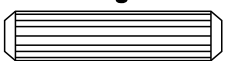

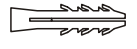

Largura / Ancho / Width - 2610mm

Peso Líquido / Peso Neto / Net Weight - 78,20kg

Volume / Volumen - 02

FERRAGENS / HARDWARE LIST / LISTA DE MATERIALES

A - Parafuso/Tornillo/Screw - 5,5 x 50mm - 06 un.

B - Parafuso/Tornillo/Screw - 4,5 x 40mm - 54 un.

C - Parafuso / Tornillo / Screw - 3,5 x 25mm - 12 un.

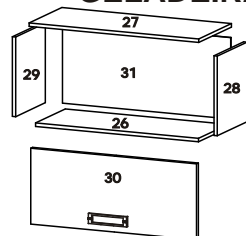
D - Parafuso / Tornillo / Screw - 4,0 x 14mm - 66 un.

E - Parafuso / Tornillo / Screw - 4,0 x 14mm - 04 un.

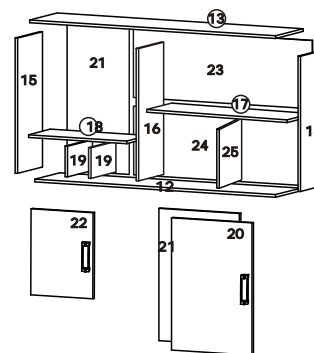
F - Prego / Clavo / Nail - 10 x 10 - 133 un.

G - Cavilha / Tarugo / Dowel - 6x30mm - 68 un.

H  Junção fundo/Unión fondo/ Joints - 30 un.	I  Puxador/Manijas Handles - 06 un.	J  Puxador/Manijas Handles - 02 un.
K  Pé / Pie / Foot - 04 un.	L  Cantoneira /Esquinera Corner - 06 un	M  Bucha - 06 un
O  Calço / Suporte p/ bisagra Clock - 7mm - 12 un.	P  Dobradilha / Bisagra Joints - 12 un.	S  Kit porta de correr - 02 un
Q  Parafuso união/Tornillo unión / Joint screw - 04 un.	R  Logo/Logo/Logo - 01 un	
T  Kit Trilho/ Kit Trillo Rail kit - 04 un	U  Parada de Porta - 02 un	

ARMÁRIO GELADEIRA



ARMÁRIO TRIPLO



PANELEIRO DUPLO

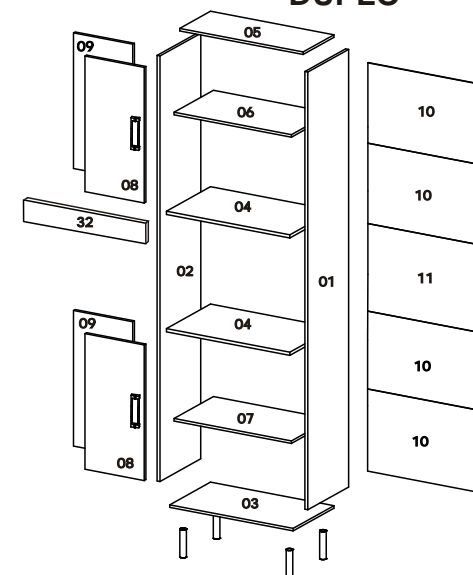

Descrição peças / Descripción piezas / Piece description

AMENDOIA ROVERE 1060.2	ROVERE AMENDOIA 1061.2	Branco Preto 1071.2	Branco Cinza Preto 1072.2	Nº	Característica	Dim (mm)	Matéria-Prima	Qtd
PANELEIRO DUPLO								
PL3024	PL3030	PL3036	PL3036	01	Lateral direita	1910x385	MDP 15mm	01
PL3025	PL3031	PL3037	PL3037	02	Lateral esquerda	1910x385	MDP 15mm	01
PB2534	PB3271	PB2371	PB2371	03	Base	0706x385	MDP 15mm	01
PR2900	PR2905	PR2654	PR2654	04	Prateleira	0675x385	MDP 15mm	02
PR2683	PR2906	PR2655	PR2655	05	Tampo microondas	0675x385	MDP 15mm	01
PR2901	PR2907	PR2656	PR2656	06	Prateleira	0675x365	MDP 15mm	01
PR2902	PR2908	PR2657	PR2657	07	Prateleira	0675x365	MDP 15mm	01
PP3269	PP3273	PP2851	PP2852	08	Porta	0668x334	MDP 15mm	02
PP3269	PP3273	PP2853	PP2853	09	Porta	0668x334	MDP 15mm	02
PF3097	PF3102	PF2850	PF2850	10	Fundo	0700x347	MDP 03mm	04
PF3098	PF3103	PF3107	PF3107	11	Fundo	0700x529	MDP 03mm	01
PV0248	PV0249	PV0250	PV0250	32	Vista Paneleiro	0675x075	MDP 15mm	01
ARMÁRIO TRIPLO								
PB2535	PB3272	PB2372	PB2372	12	Base	1170x300	MDP 15mm	01
PC2336	PC2338	PC2220	PC2220	13	Chapéu	1170x300	MDP 15mm	01
PL3028	PL3034	PL2744	PL2744	14	Lateral direita	0696x300	MDP 15mm	01
PL3029	PL3035	PL2745	PL2745	15	Lateral esquerda	0696x300	MDP 15mm	01
PD2711	PD2714	PD2505	PD2505	16	Divisão	0664x300	MDP 15mm	01
PR2904	PR2910	PR2659	PR2659	17	Prateleira	0771x235	MDP 15mm	01
PR2903	PR2909	PR2658	PR2658	18	Prateleira	0384x300	MDP 12mm	01
PD2710	PD2713	PD2506	PD2506	19	Divisão	0300x150	MDP 15mm	02
PP3267	PP3271	PP2854	PP2855	20	Porta correr	0656x393	MDP 15mm	01
PP3267	PP3271	PP2856	PP2856	21	Porta correr	0656x393	MDP 15mm	01
PP3268	PP3272	PP2857	PP2858	22	Porta	0492x379	MDP 15mm	01
PF3099	PF3104	PF2852	PF2852	23	Fundo	0689x404	MDP 03mm	01
PF3100	PF3105	PF2853	PF2853	24	Fundo	0790x344	MDP 03mm	02
PD2712	PD2715	PD2622	PD2622	25	Divisão arm. triplo	0324x205	MDP 15mm	01
ARMÁRIO GELADEIRA								
PB2536	PB3273	PB2373	PB2373	26	Base	0675x300	MDP 15mm	01
PC2337	PC2339	PC2221	PC2221	27	Chapéu	0675x300	MDP 15mm	01
PL3026	PL3032	PL2746	PL2746	28	Lateral direita	0244x300	MDP 15mm	01
PL3027	PL3033	PL2785	PL2785	29	Lateral esquerda	0244x300	MDP 15mm	01
PP3270	PP3274	PP2859	PP2860	30	Porta	0668x206	MDP 15mm	01
PF3101	PF3106	PF2854	PF2854	31	Fundo	0700x239	MDP 03mm	01

ASPECTO MONTADO

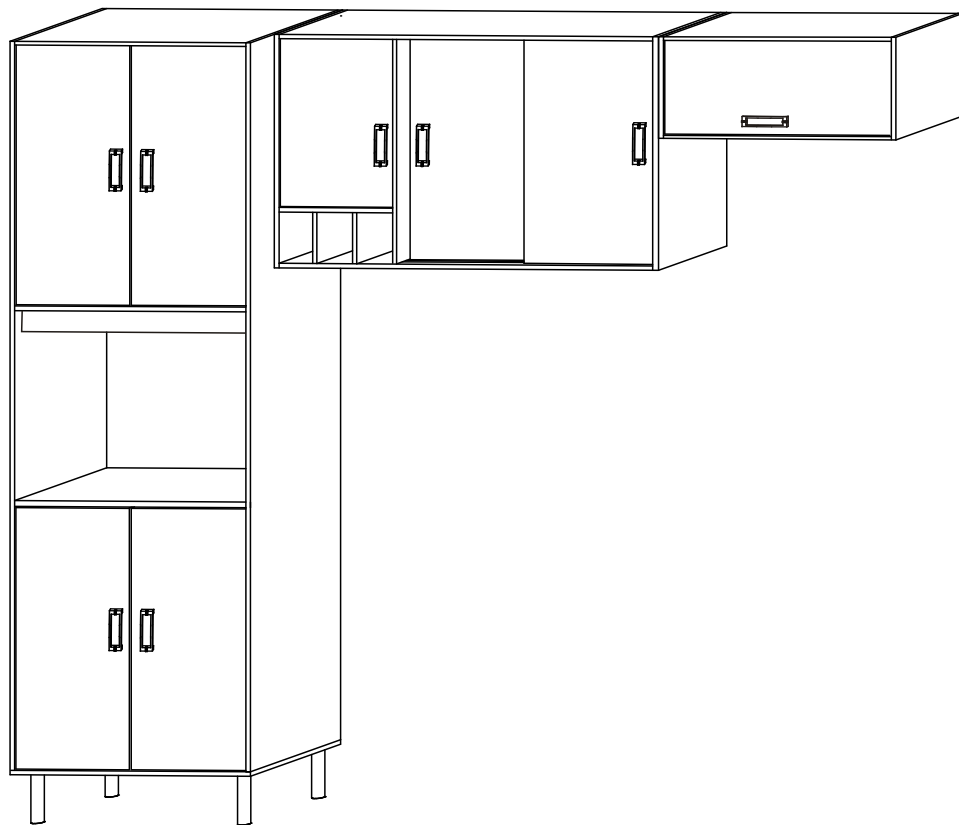

**ETAPA DE PREPARAÇÃO DAS PEÇAS.
STAGE OF PREPARATION OF THE PIECES.
FASE DE PREPARACIÓN DE LAS PIEZAS.**







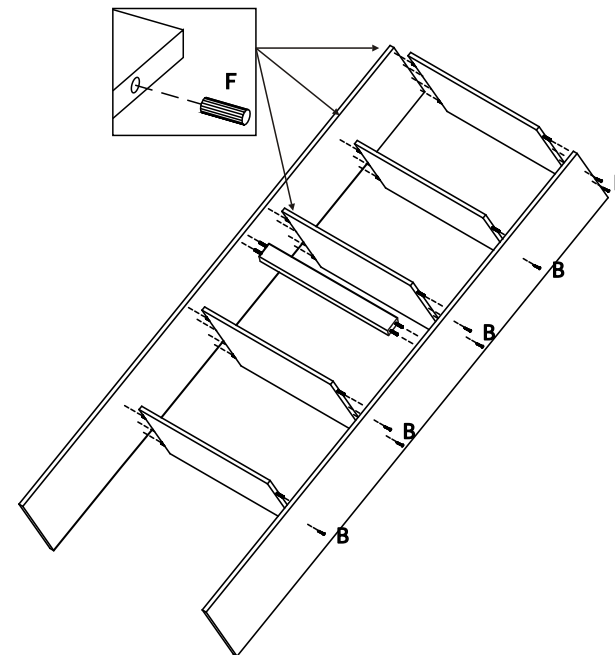
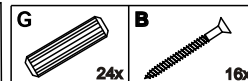

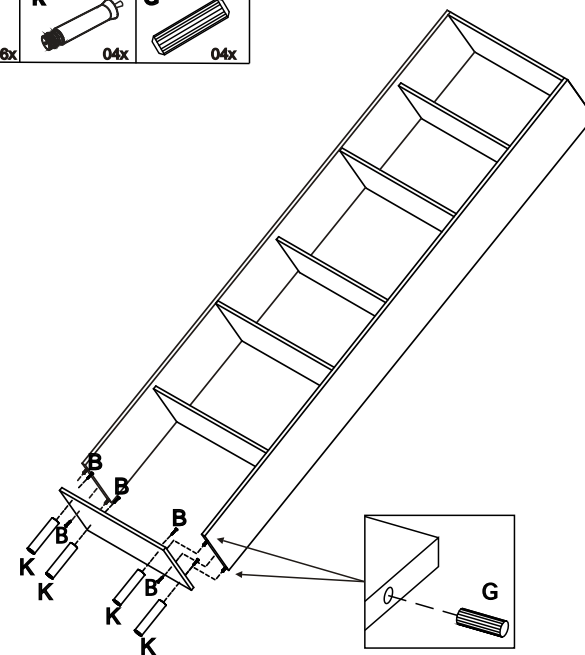

**PREPARE TODAS AS PEÇAS ANTES DE INICIAR A MONTAGEM.
PREPARE ALL THE PIECES BEFORE BEGINNING THE ASSEMBLY.
PREPARAR TODAS LAS PIEZAS ANTES DE INICIAR EL MONTAJE.**

1
Passo
Step
Paso





2
Passo
Step
Paso



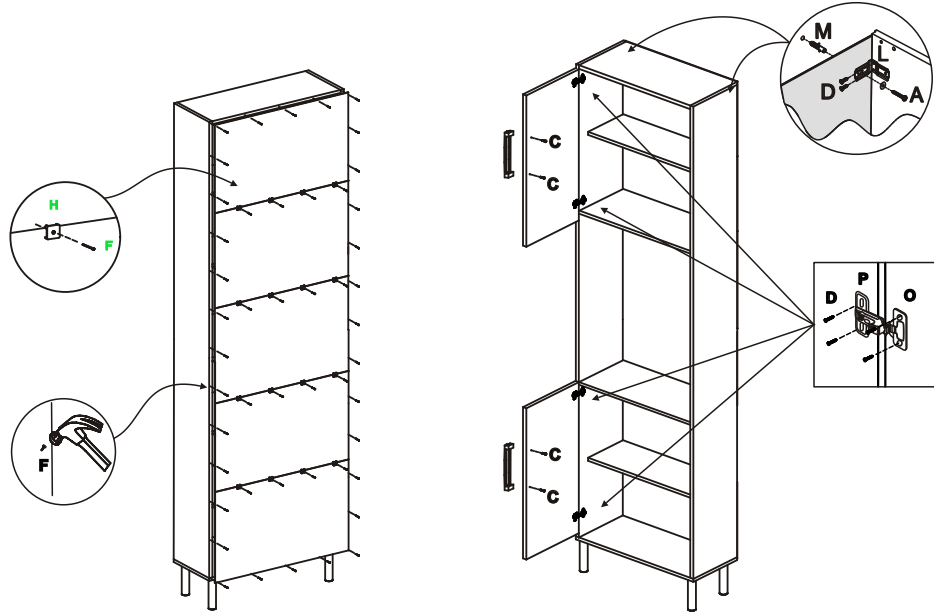

- 3** Passo Step Paso
- O**  08x
 - P**  08x
 - D**  3,5x12mm 28x
 - C**  3,5x25mm 04x
 - I**  04x
 - H**  20x
 - F**  50x



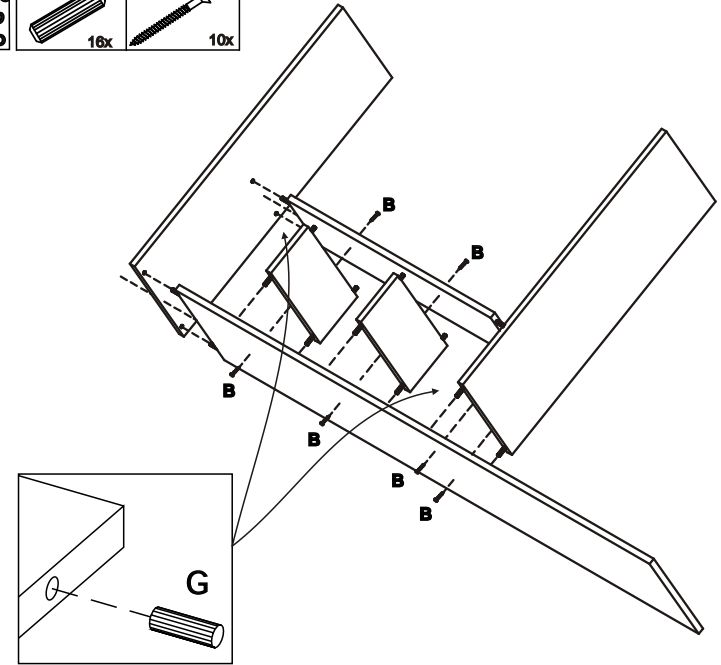

- 4** Passo Step Paso
- G**  16x
 - B**  10x

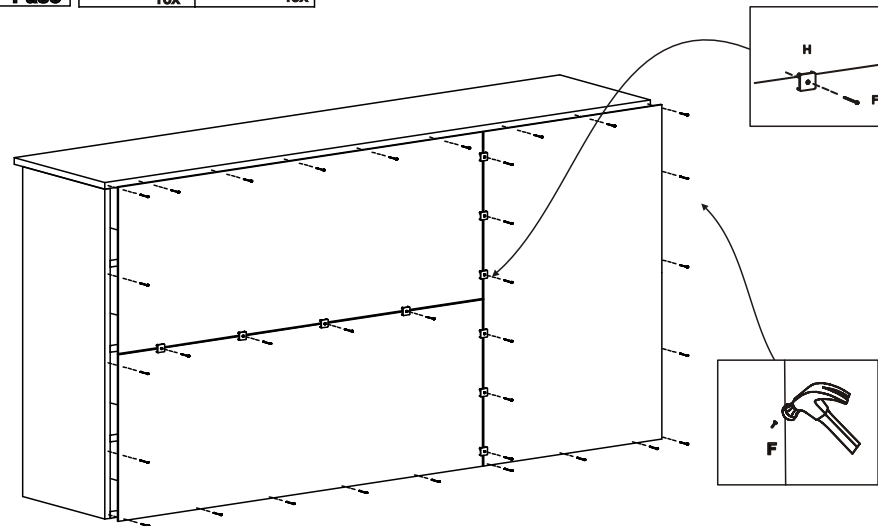

- 6** Passo Step Paso
- H**  10x
 - F**  40x



- 5** Passo Step Paso
- G**  12x
 - B**  12x

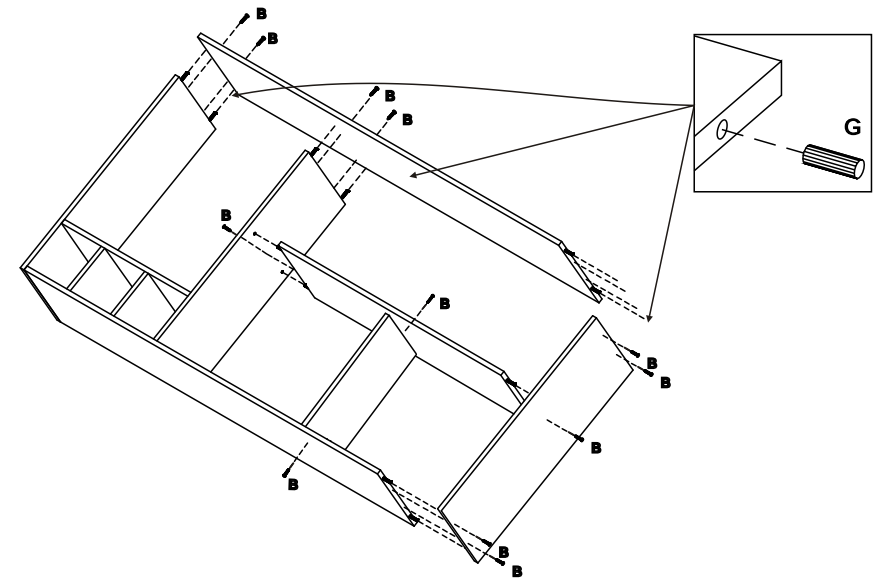

- 7** Passo
Step
Paso
- | | | | | | | |
|-----|-----|-----|-----|-----|-----|-----|
| O | P | D | I | J | L | M |
| | | | | | | |
| 02x | 02x | 12x | 01x | 02x | 02x | 02x |
- | | | |
|-----|-----|-----|
| A | S | E |
| | | |
| 02x | 02x | 04x |

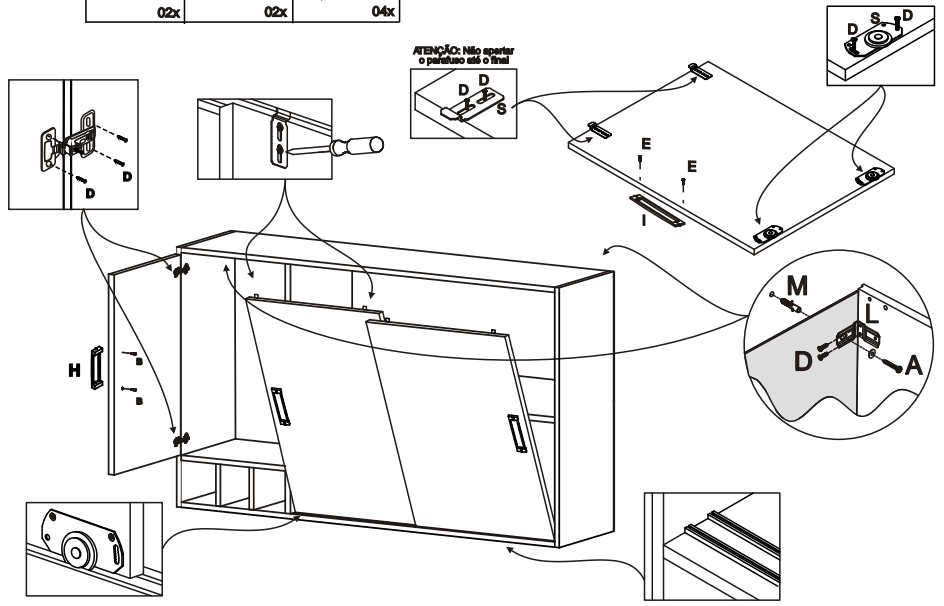

- 8** Passo
Step
Paso
- | | | |
|-----|-----|-----|
| G | B | F |
| | | |
| 06x | 06x | 20x |

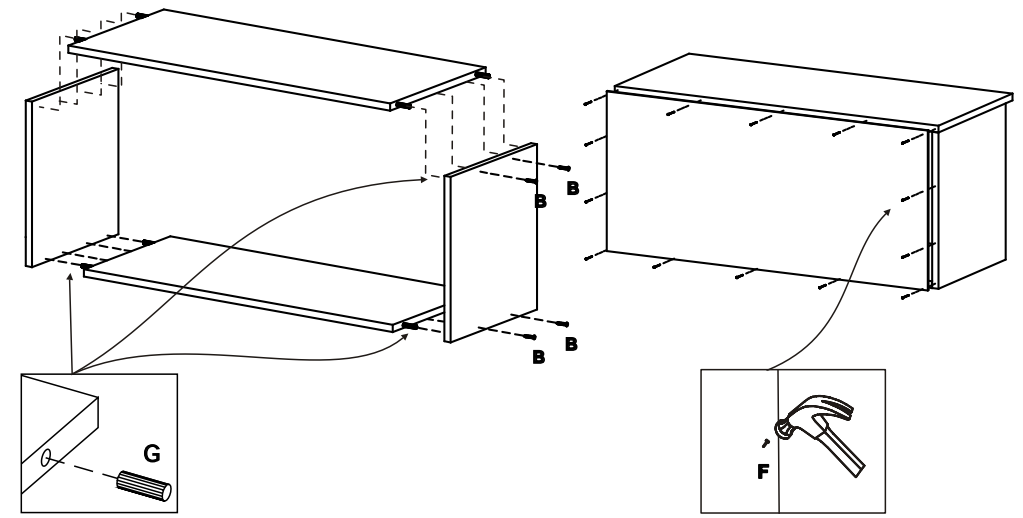

- 9** Passo
Step
Paso
- | | | | | | | |
|-----|-----|-----|-----|-----|-----|-----|
| O | P | D | C | I | L | M |
| | | | | | | |
| 02x | 02x | 12x | 02x | 01x | 02x | 02x |
- | |
|-----|
| A |
| |
| 02x |

