

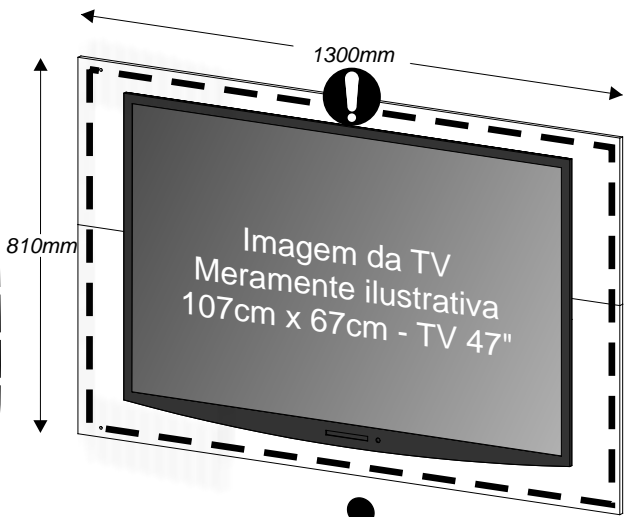

Para televisores de ATÉ 55"
*Verifique o tamanho do seu
 Televisor x Dimensões do Painel*
Para televisores de hasta 55 "
*Comprueba el tamaño de tu
 TV x dimensiones del panel*
For TVs up to 55 "
*Check the size of your
 TV x Panel Dimensions*

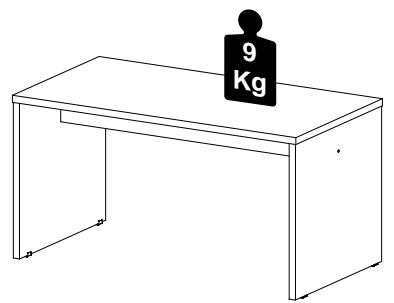

COBRIR OS PARAFUSOS
TAMPA ADESIVA
TAPA ADESIVA
STICKER
 TAPA LOS TORNILLOS / COVER THE SCREWS

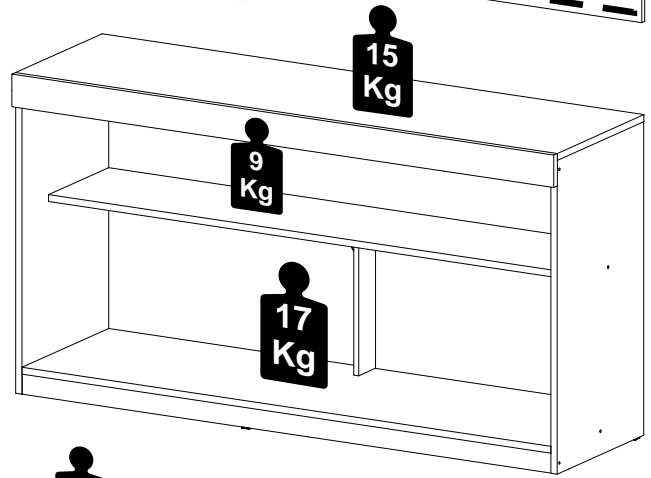

INSTRUÇÕES DE MONTAGEM
INSTRUCCIONES DE ARMADO
ASSEMBLY INSTRUCTIONS



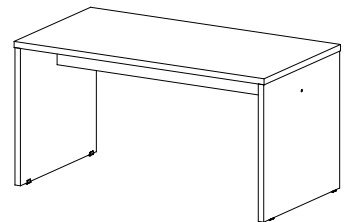
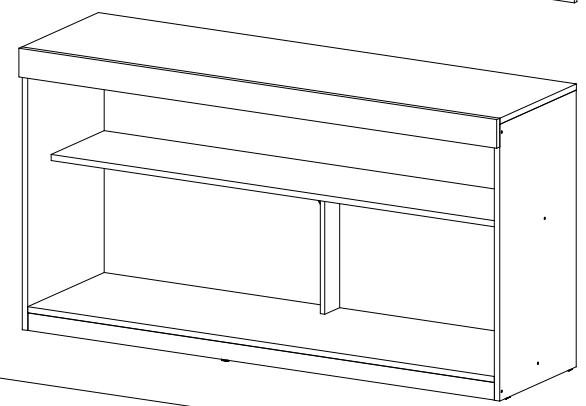
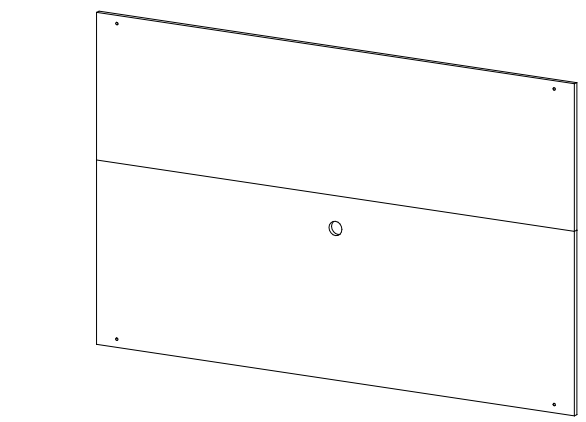



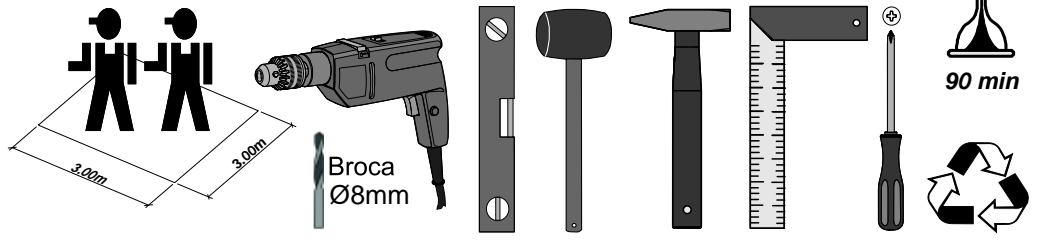







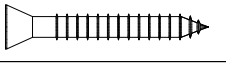

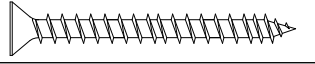
REF.: 990

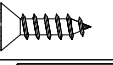
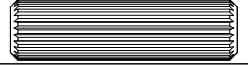
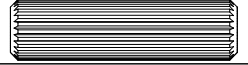

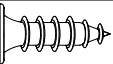
FERRAMENTAS NECESSÁRIAS
HERRAMIENTAS NECESARIAS
TOOLS NECESSARY

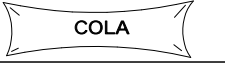

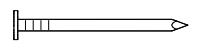
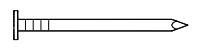
Passo
Paso
Step **08**

| | | | |
|----|---|---|----|
| A |  |  5,0 x 80 | 04 |
| B |  |  4,5 x 50 | 10 |
| BA |  |  4,0 x 25 | 11 |
| BZ |  | | 09 |
| C |  |  4,0 x 40 | 01 |
| CC |  |  3,5 X 12 | 18 |
| H |  |  8,0 x 30 | 21 |
| F |  |  3,5 x 14 | 04 |
| AT |  | | 09 |
| BX |  | COLA | 01 |
| BQ |  | | 02 |
| ED |  | Tampa Adesiva Papel | 14 |
| Y |  |  10 x 10 | 44 |
| AE |  | | 07 |
| X |  | Bucha Ø8mm | 04 |

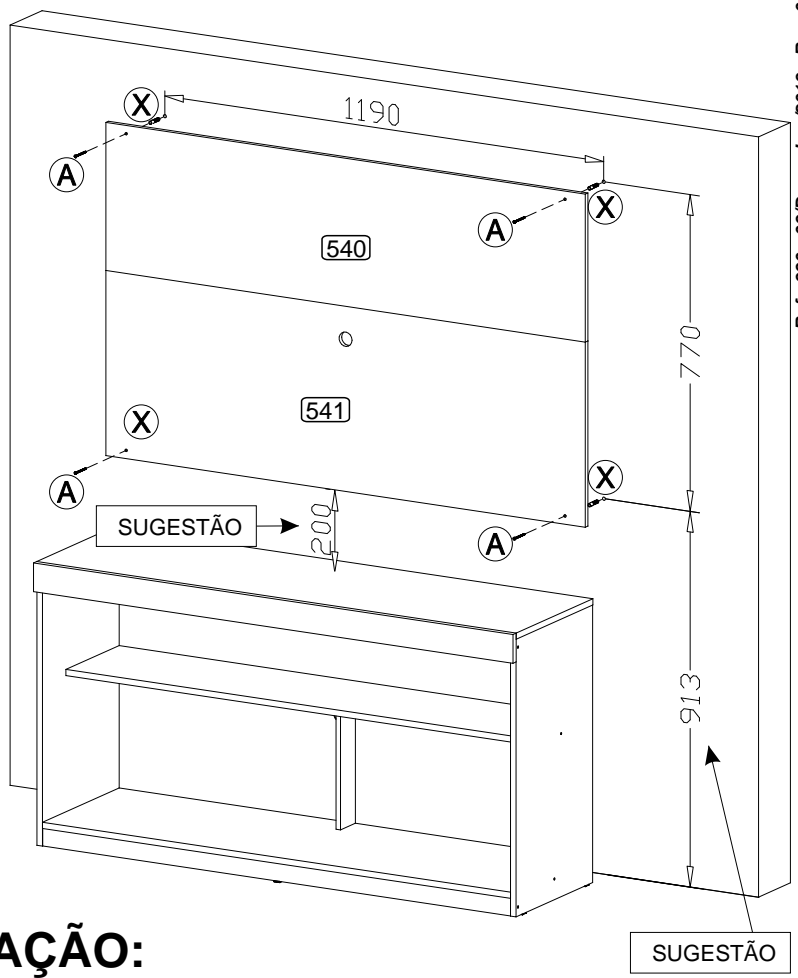
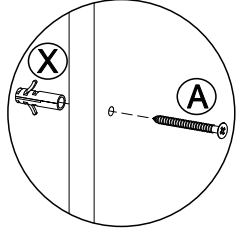
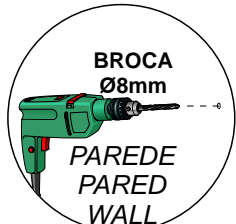

OBSERVAÇÃO:
É OBRIGATÓRIO fixar o painel na parede. Na imagem acima, está informado as medidas entre furos do painel e uma sugestão para a instalação. Durante montagem será necessário a utilização de uma furadeira e um nível para alinhá-lo.

Es **OBLIGATORIO** fijar el panel a la pared. En la imagen de arriba, se le informa de las medidas entre los orificios del panel y una sugerencia para la instalación. Durante el montaje será necesario utilizar un taladro y un nivel para alinearlo.

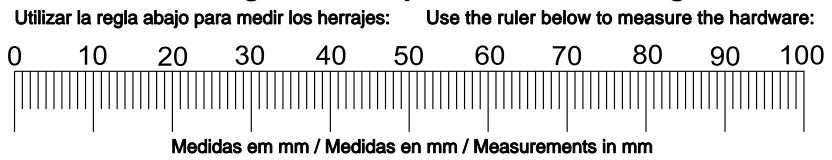

IT IS MANDATORY Attach the panel to the wall. In the image above, you are informed of the measurements between panel holes and a suggestion for installation. During assembly, you will need to use a drill and a level to align it.

Utilizar a régua abaixo para medir as ferragens:

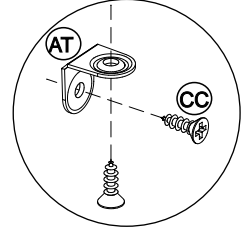
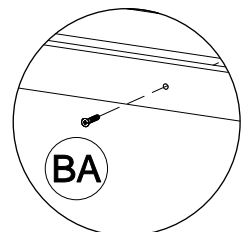
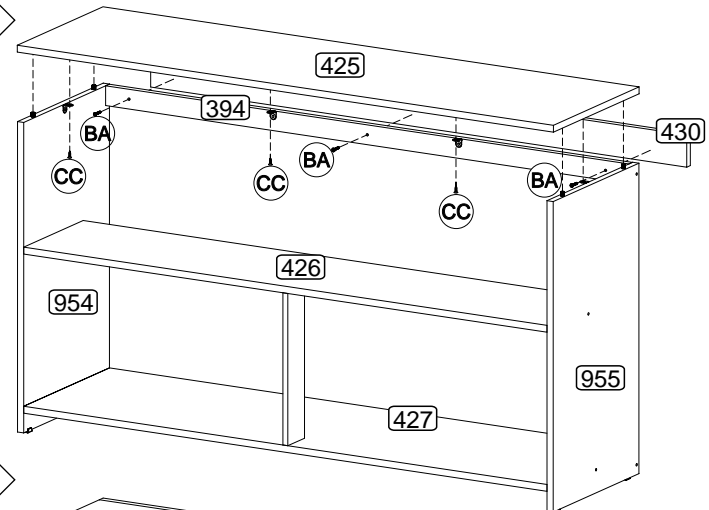

Passo
Paso
Step **05**



 

Senhor montador!
Informamos que a numeração das peças encontra-se no topo das mesmas conforme desenho acima.

Señor Armador!
Les informamos que la numeración de las piezas encuentranse arriba de las mismas, de acuerdo al modelo arriba.

Dear Assembler!
We inform you that the number of each piece is located on the top of it, according to the model shown above.

Passo
Paso
Step **06**

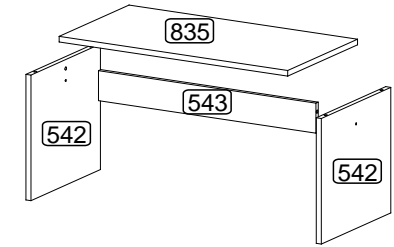
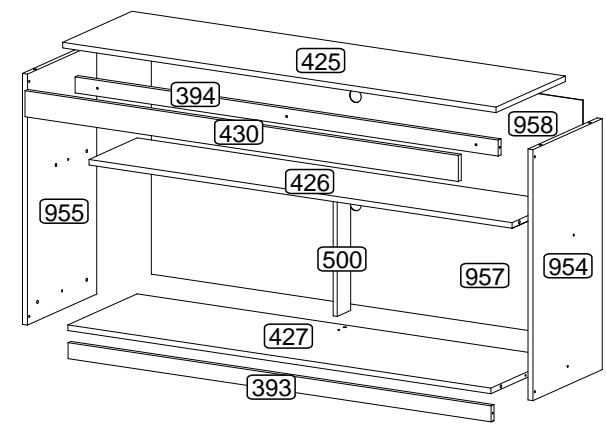
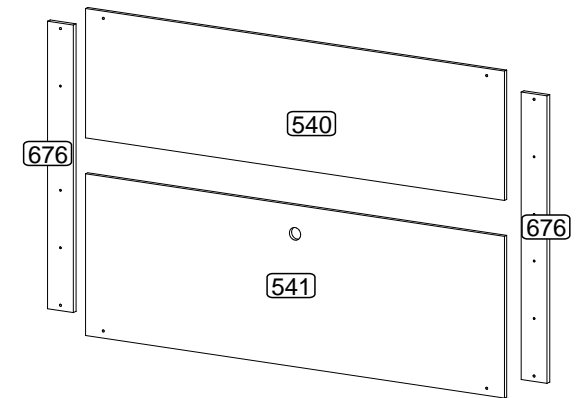
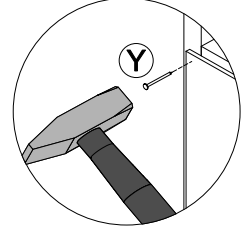
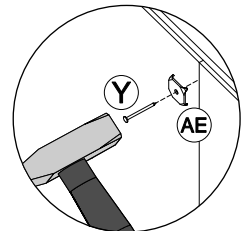
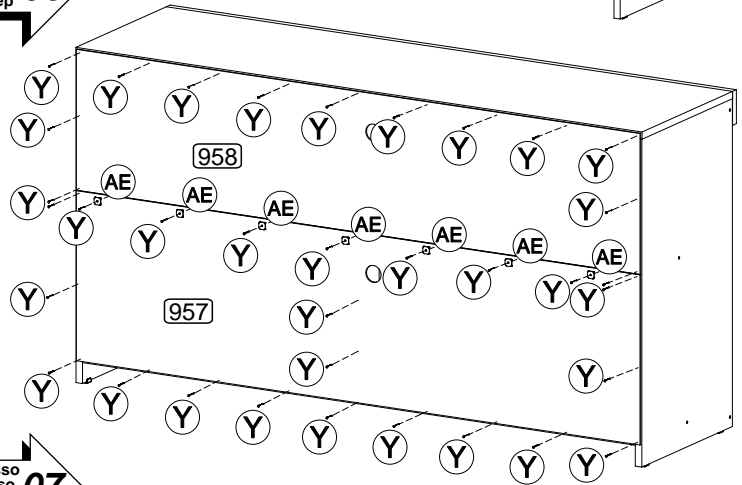

Passo
Paso
Step **07**

Alinhar os furos passantes
Alinear los agujeros pasantes
Align the through holes

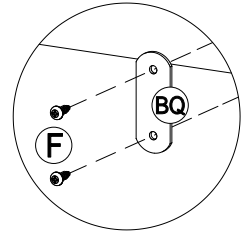
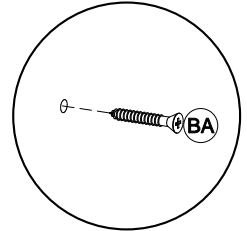
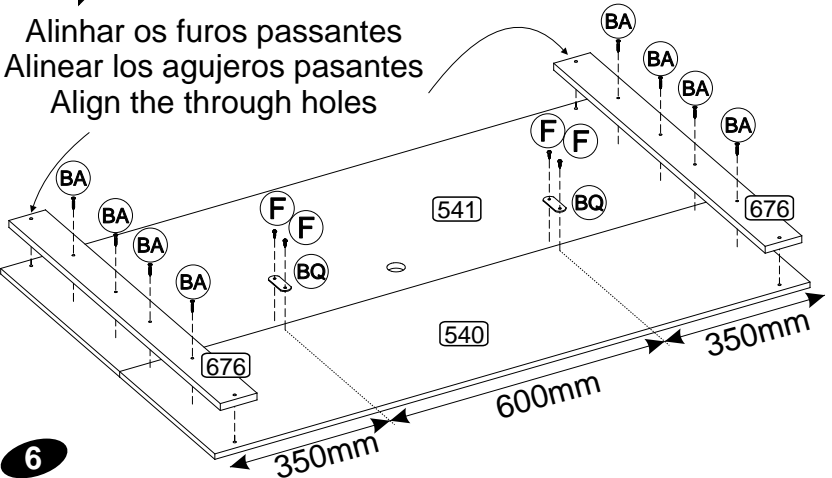

POR

LISTA DE PEÇAS
Nº DENOMINAÇÃO

- 393 - RODAPÉ
- 394 - MOLDURA
- 676 - TRAVESSA
- 540 - PAINEL
- 541 - PAINEL C/ FURO
- 542 - LATERAL
- 543 - TRAVESSA MENOR
- 835 - TAMPO MENOR
- 425 - TAMPO
- 426 - PRATELEIRA
- 427 - BASE
- 954 - LATERAL DIREITA
- 955 - LATERAL ESQUERDA
- 430 - MOLDURA MAIOR
- 500 - PILASTRA
- 958 - COSTA C/ FURO MENOR
- 957 - COSTA C/ FURO MAIOR

ESP

LISTA DE PIEZAS
Nº DENOMINACIÓN

- 393 - ZÓCALO
- 394 - MOLDURA
- 676 - TRAVIESA
- 540 - PANEL
- 541 - PANEL CON AGUJERO
- 542 - LATERAL
- 543 - TRAVIESA MENOR
- 835 - TAPA MENOR
- 425 - TAPA
- 426 - ESTANTE
- 427 - BASE
- 954 - LATERAL DERECHA
- 955 - LATERAL IZQUIERDA
- 430 - MOLDURA MAYOR
- 500 - PILASTRA
- 958 - RESPALDO CON AGUJERO MENOR
- 957 - RESPALDO CON AGUJERO MAYOR

ENG

PART LIST
Nº DESCRIPTION

- 393 - SKIRTING BOARD
- 394 - FRAME
- 676 - CROSS BAR
- 540 - PANEL
- 541 - PANEL WITH HOLE
- 542 - SIDE
- 543 - SMALL CROSS BAR
- 835 - SMALLER TOP
- 425 - TOP
- 426 - SHELF
- 427 - BASE
- 954 - RIGHT SIDE
- 955 - LEFT SIDE
- 430 - LARGER FRAME
- 500 - DOOR STOP
- 958 - BACK SMALLER HOLE
- 957 - BACK LARGER HOLE

PRÉ-MONTAGEM / PRÉ-ARMADO / PRÉ-ASSEMBLAGE

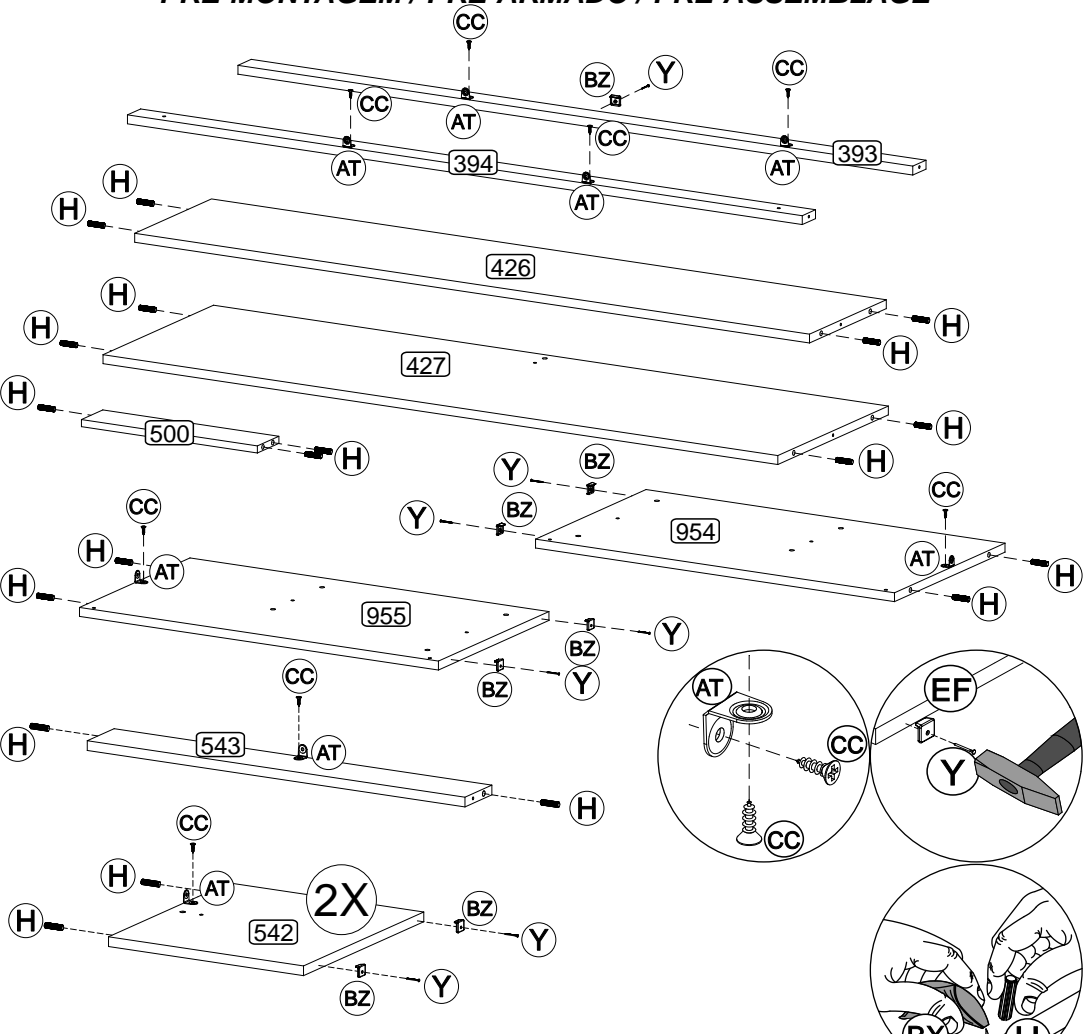

Passo
Paso
Step
01

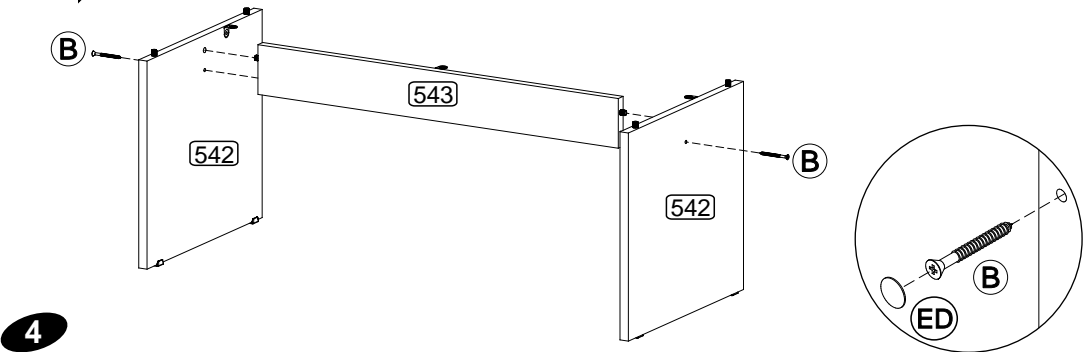

4

Passo
Paso
Step
02

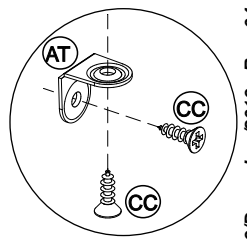
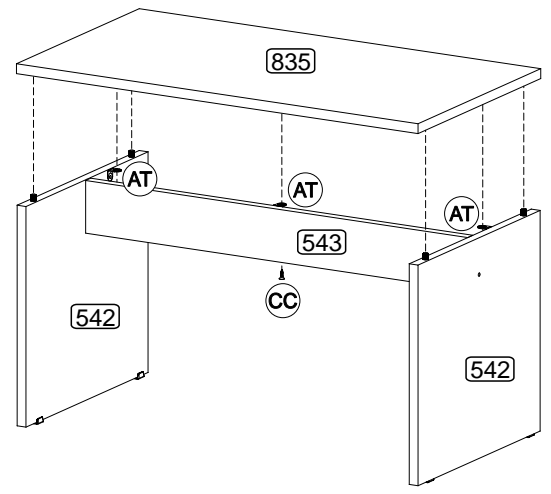

Passo
Paso
Step
03

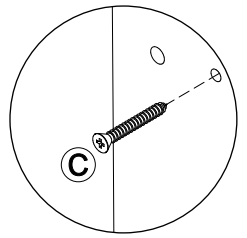
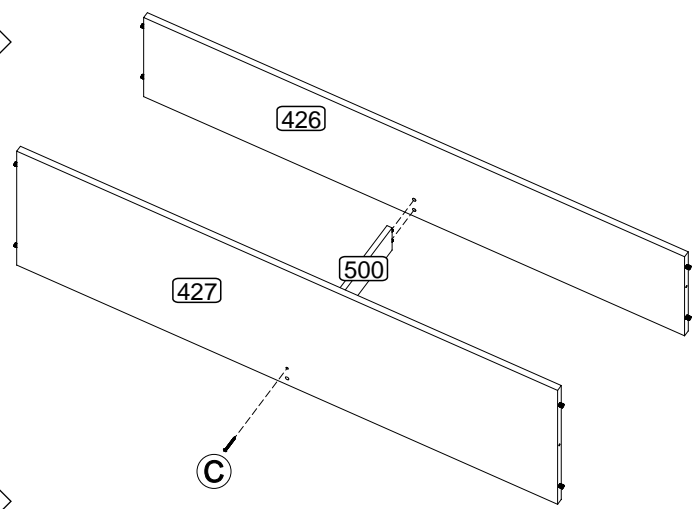

Passo
Paso
Step
04

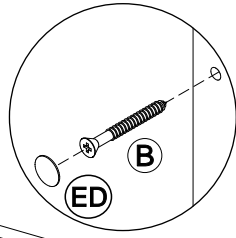
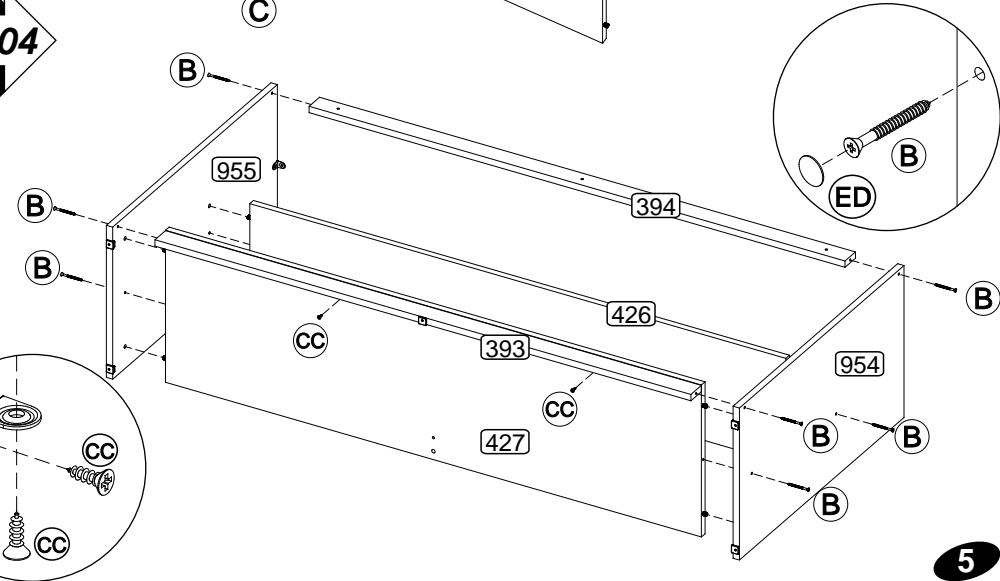

5