

MANUAL DE MONTAGEM
Assembly instructions / Instrucciones de armado

MESA HANOVER

Hanover Office table
Escritorio Hanover

Código 170036 | Revisão 01

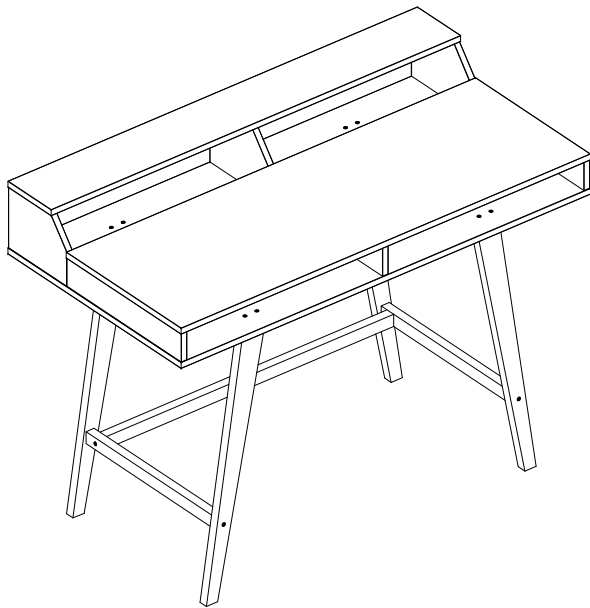

PESO MÁXIMO SUPORTADO PELAS PEÇAS, SENDO ESTE DISTRIBUÍDO UNIFORMEMENTE.

Maximum weight supported by parts, being this evenly distributed.
Peso máximo soportado por las partes, siendo esta distribuido uniformemente.

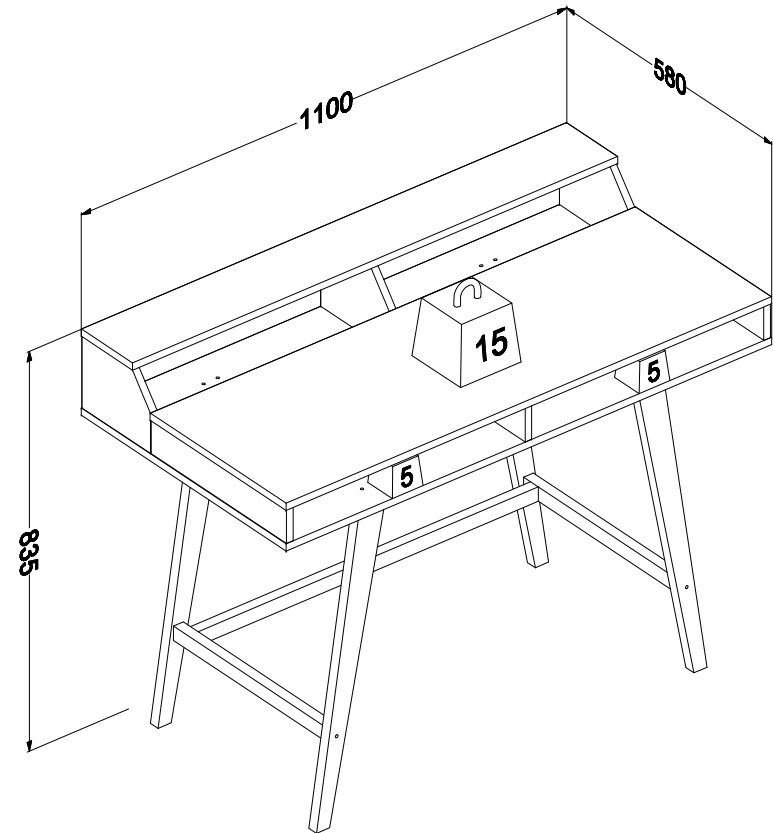

Você vai precisar de/ You will need / Usted necesitará

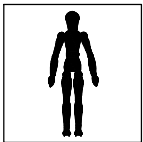

1 Pessoa
1 Person
1 Persona

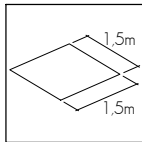

Espaço recomendado para montagem
Recommended space for assemble
Espacio recomendado para el armado

Ferramentas não inclusas
Tools not included / Herramientas no incluidas

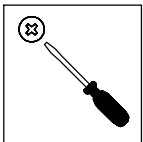

Chave Philips
Screwdriver
Destornillador cruz







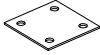
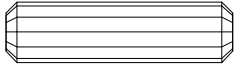
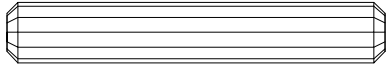
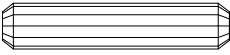
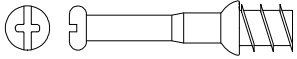
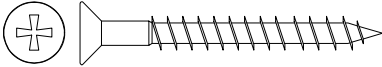

Martelo
Hammer
Martillo

* PESO EM KG/ Weight in Kg/ Peso en Kg
DIMENSÕES EM MM/ Dimensions in mm/ Dimensiones en mm

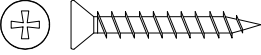
IDENTIFICAÇÃO DOS ACESSÓRIOS/ IDENTIFICATION OF ACCESSORIES/ IDENTIFICACIÓN DE ACCESORIOS

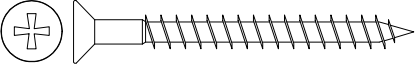
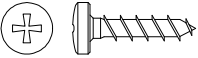
NOTAS: A separação dos acessórios antes de iniciar a montagem facilitará a mesma. Os parafusos e cavilhas estão na escala real. Em caso de dúvida na identificação, coloque o acessório sobre a imagem.
NOTES: The separation of the accessories before you start the assembly will facilitate the same. The screws and dowels are in real scale. In case of doubts about the identification, place the accessory on the image.
NOTAS: La separación de los accesorios antes de comenzar el armado facilitará el mismo. Los tornillos y taquetes son en escala real. En caso de dudas sobre la identificación, coloque el accesorio en la imagen.

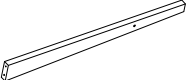
A1		Cola Glue Pegamento	13g	01
B6		Junção de tampos Junction of tops Unión de tapas	40x40 mm	03
E		Cavilha Wooden Dowel Pin	8x30 mm	34
F		Cavilha Wooden Dowel Taquete	8x50 mm	02
F1		Cavilha Wooden Dowel Taquete	6x30 mm	08
J		Haste minifix simples Simple minifix screw Tornillo minifix simple	-	09
K6		Parafuso chato Flat head screw Tornillo de cabeza plana	4,5x40 mm	08
L		Tambor minifix Drum lock Tambor minifix	12 mm	09
M		Tapa furo adesivo Bore patch adhesive Tapones adhesivo	-	09
M1		Parafuso chato Flat head screw Tornillo de cabeza plana	3,5x25 mm	02
N		Prego Nail Clavo	10 x10	24
O		Parafuso chato Flat head screw Tornillo de cabeza plana	4,5x45 mm	15
S		Parafuso panela Pan head screw Tornillo de pan	3,5x14 mm	12
Y6A		Sapata Foot Pie	655mm	02
Y6B		Sapata Foot Pie	655mm	02

IDENTIFICAÇÃO DAS PEÇAS/ PARTS IDENTIFICATION/ IDENTIFICACIÓN DE LAS PIEZAS

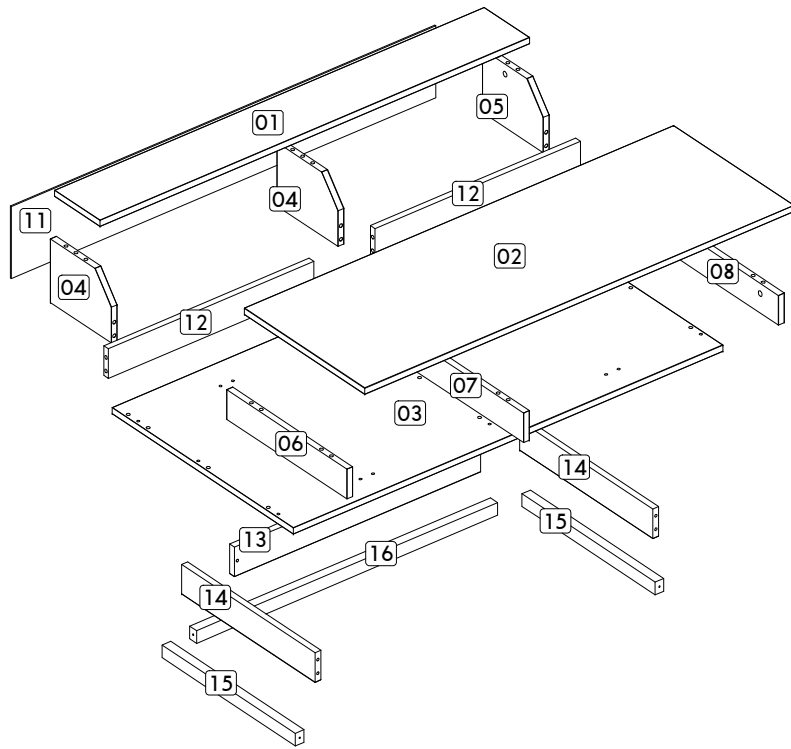

Nº	DESCRIÇÃO - DESCRIPTION - DESCRIPCIÓN	MEDIDAS - MEASURES - MEDIDAS (mm)	QTD.
01	Base superior - Top base - Base superior	1100 x 145 x 15	01
02	Tampo - Top - Tapa	1100 x 385 x 15	01
03	Base inferior - Bottom base - Base inferior	1100 x 580 x 15	01
04	Lateral esq/divisão traseira - Back division/left side - Lateral izq/division trasera	150 x 195 x 15	02
05	Lateral direita traseira - Back right side - Lateral derecha trasera	150 x 195 x 15	01
06	Lateral esquerda frontal - Front left side - Lateral izquierda frontal	70 x 384 x 15	01
07	Divisão frontal - Front division - Division frontal	70 x 384 x 15	01
08	Lateral direita frontal - Front right side - Lateral derecha frontal	70 x 384 x 15	01
11	Costa - Backboard - Fondo	1087 x 170 x 03	01
12	Travessa - Tray - Traviesa	526 x 70 x 15	02
13	Travessa traseira - Rear tray - Traviesa trasera	631 x 70 x 15	01
14	Travessa lateral - Side tray - Traviesa lateral	426 x 70 x 15	02
15	Travesa madeira - Wood tray - Traviesa madeira	426 x 30 x 22	02
16	Travesa madeira - Wood tray - Traviesa madeira	771 x 30 x 22	01

PRÉ-MONTAGEM/ PRE-ASSEMBLE/ PRE ARMADO

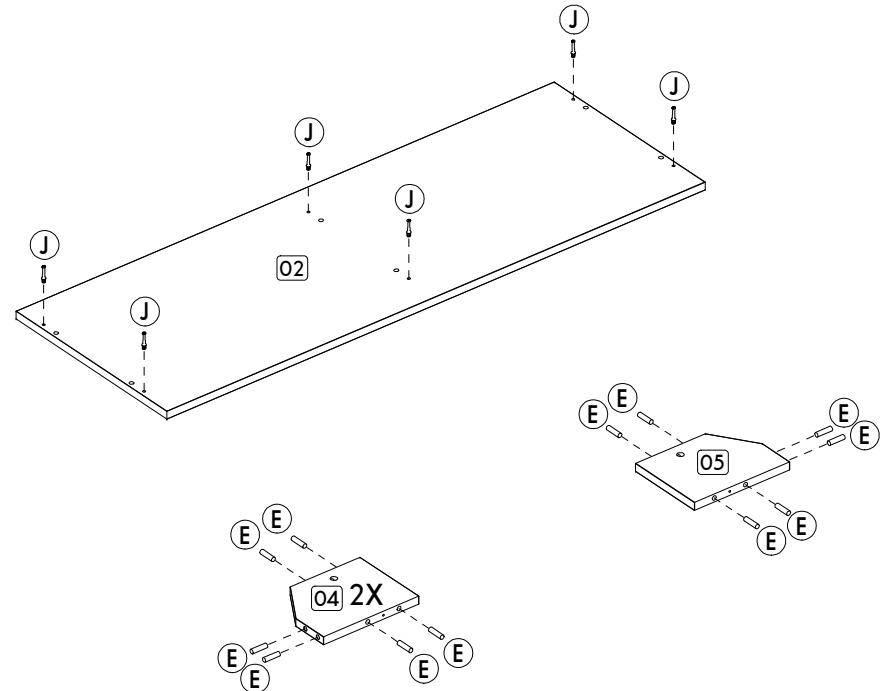
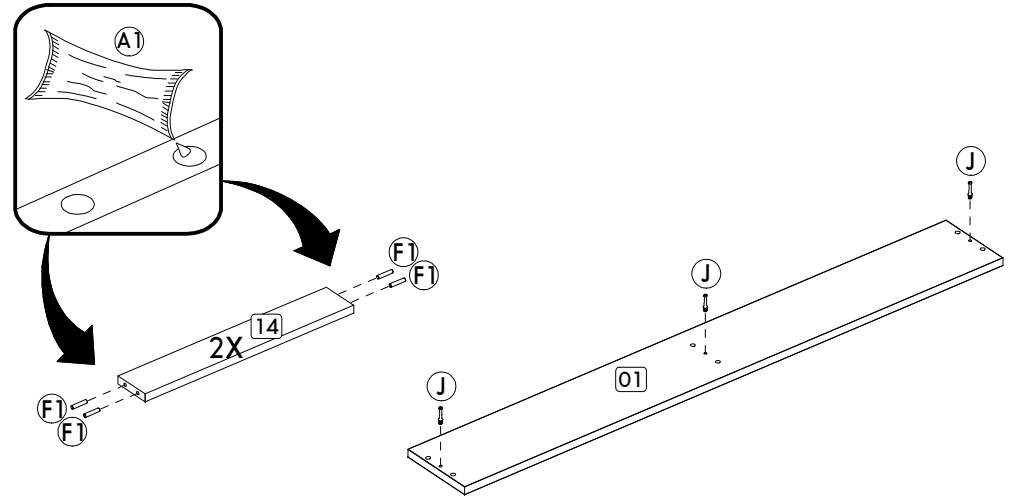

Passo/ Step/ Paso 01

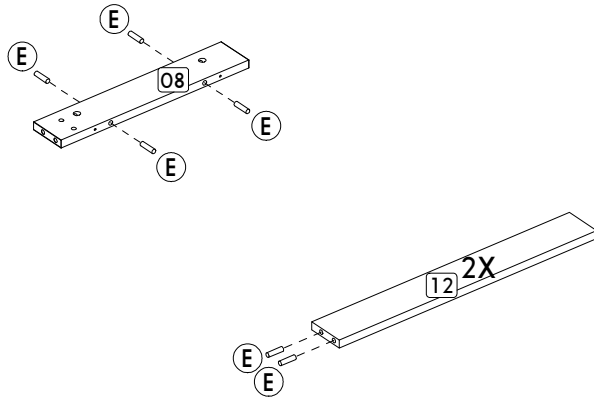

Atenção! / Attention! / Atención!

Estes furos devem ficar na mesma face de fixação do acessório B6.
 This holes must be on the same attachment faces as the B6 accessory.
 Estos agujeros deben quedar en la mismo lado de fijación del accesorio B6.

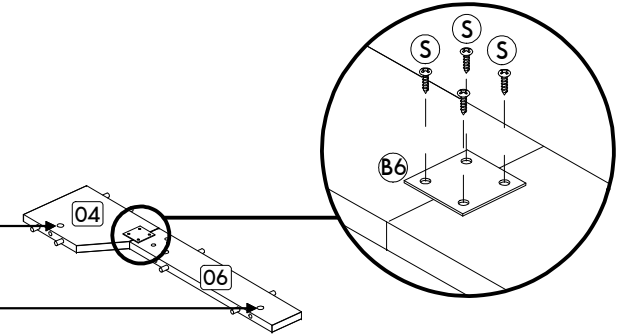
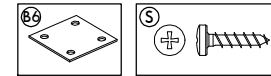

Passo/ Step/ Paso 02

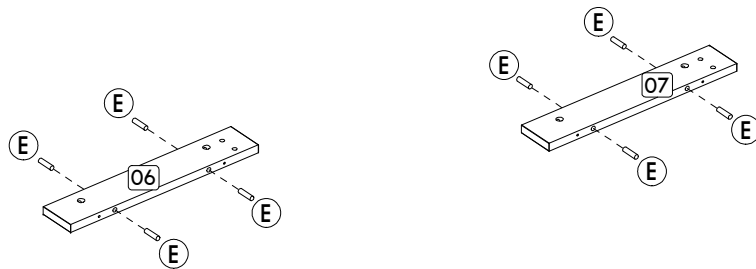

Atenção! / Attention! / Atención!

Estes furos devem ficar na mesma face de fixação do acessório B6.
 This holes must be on the same attachment faces as the B6 accessory.
 Estos agujeros deben quedar en la mismo lado de fijación del accesorio B6.

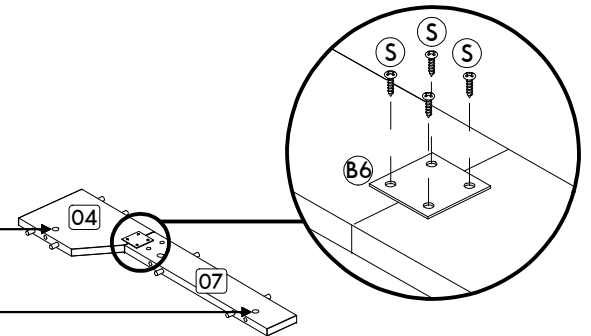
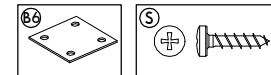

Passo/ Step/ Paso 03

Atenção! / Attention! / Atención!

Estes furos devem ficar na mesma face de fixação do acessório B6.
 This holes must be on the same attachment faces as the B6 accessory.
 Estos agujeros deben quedar en la mismo lado de fijación del accesorio B6.

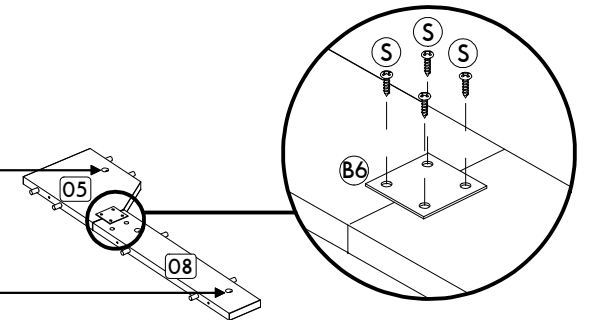
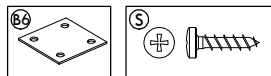

Passo/ Step/ Paso 04

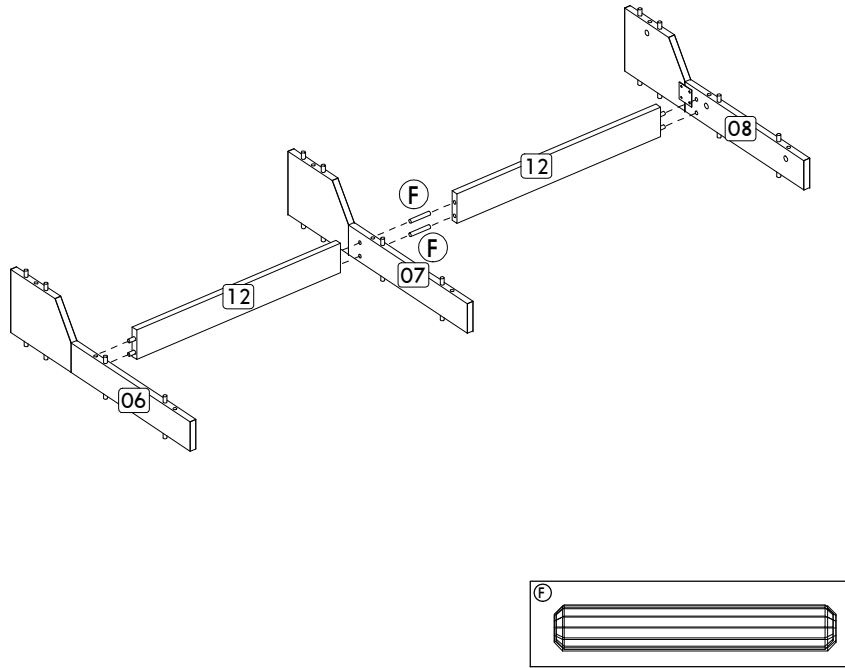

Passo/ Step/ Paso 05

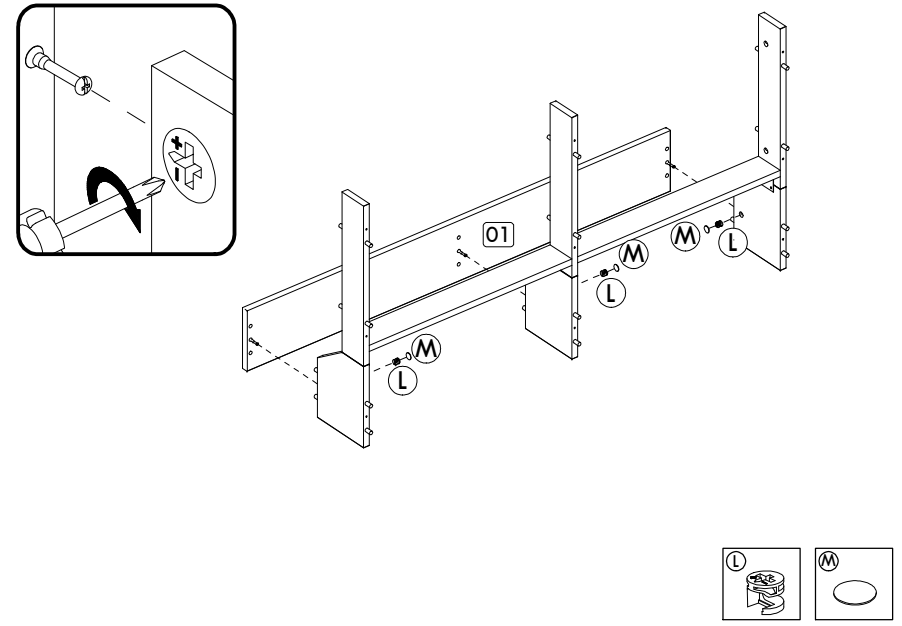

Passo/ Step/ Paso 06

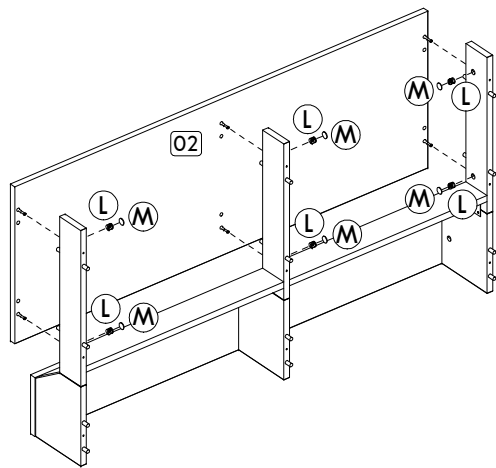

Passo/ Step/ Paso 07

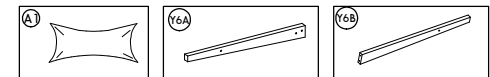
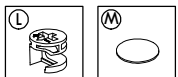
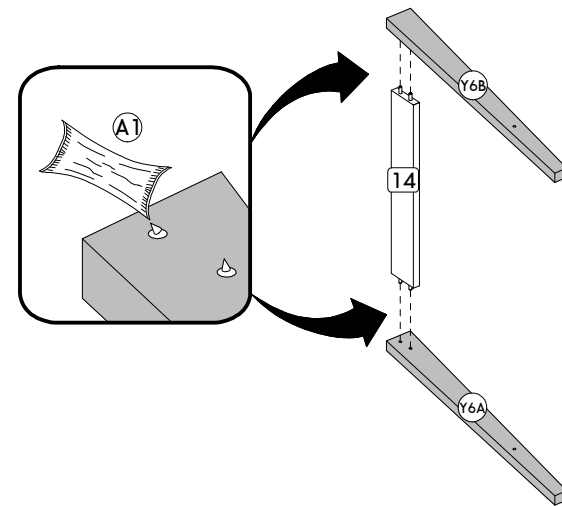

Passo/ Step/ Paso 08

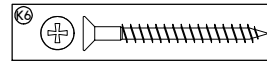
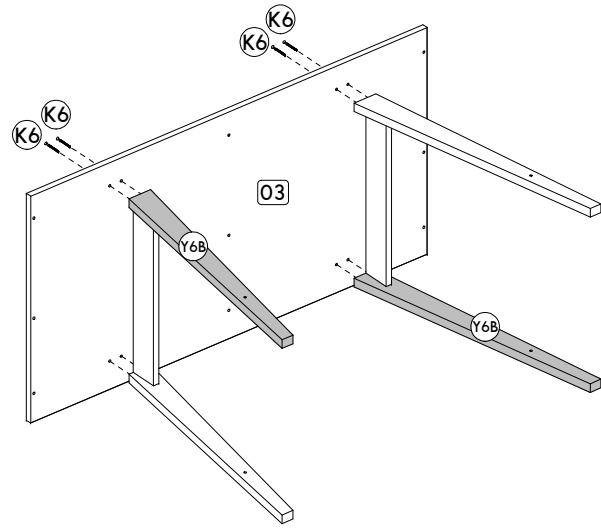

Passo/ Step/ Paso 10

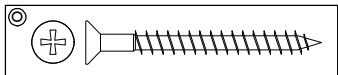
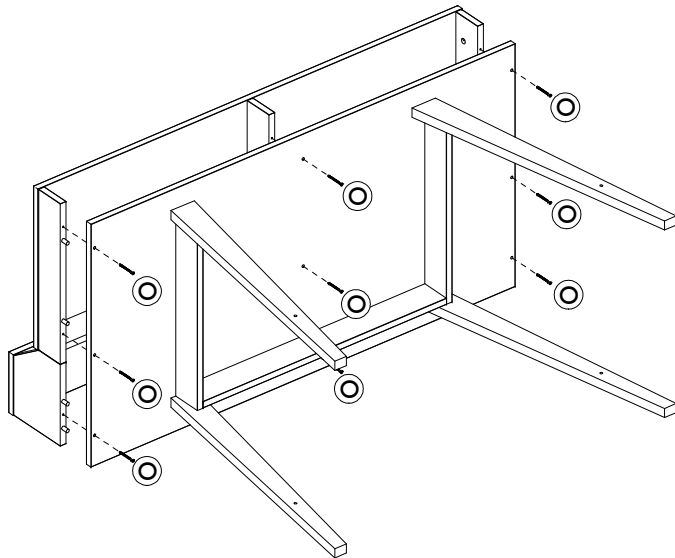

Passo/ Step/ Paso 09

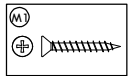
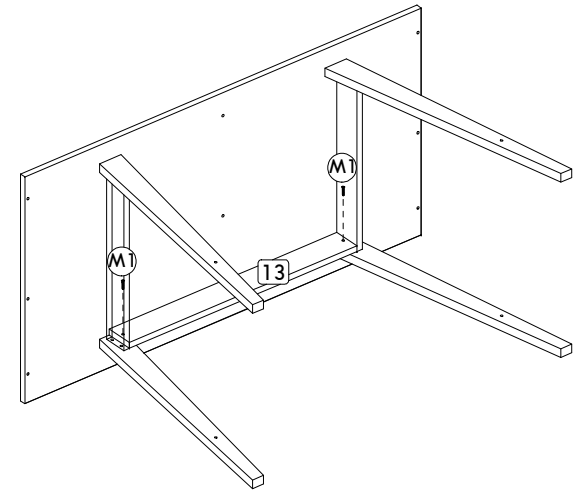

Passo/ Step/ Paso 11

