

CÓDIGO DE PEÇAS | CODE OF PIECES | CÓDIGO DE PIEZAS

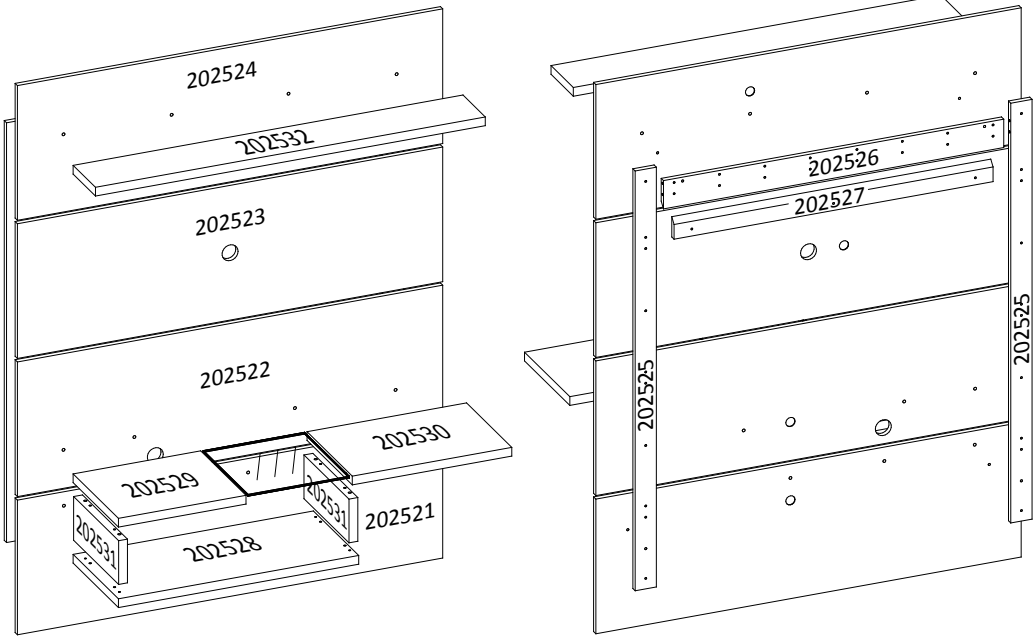

INSTRUÇÕES

- Prepare a montagem do móvel próximo ao local que ele ficará definitivamente e evite deslocá-lo depois de montado;
- Forre o chão com papelão ou similar e utilize a isomanta que vem entre as peças para evitar o contato entre elas durante a montagem;
- Monte o móvel obedecendo a ordem numérica da **seqüência de montagem (S.M.)**, identificando as peças pelo **código de peça (C.P.)** carimbado na mesma, de acordo com a tabela.

INSTRUCTIONS

- Prepare the assembly of the close piece of furniture to the place that it will be definitively and avoid to move after done. Will be definitively and avoid to move after done;
- Cover the ground with cardboard or similar and use the isomanta that it comes among the pieces to avoid the contact among them during the assembly;
- Set up the piece of furniture obeying the numeric order of the **assembly sequence (S.M.)**, identifying the pieces by **code of piece (C.P.)** stamped in the same, in agreement with the table.

INSTRUCCIONES

- Prepare la montaje del mobiliario proximo al lugar que estará definitivamente y evite mover después de hecho;
- Tape la suelo con cartón o similar y use la "isomanta" que viene entre las piezas para evitar el contacto entre ellos durante la montaje;
- Monte el mobiliario obedeciendo el orden numérico de la **sucesión de montaje (S.M.)**, identificando las piezas por el **código de piezas (C.P.)** de la misma estampado en esta, de acuerdo con la tabla .

ASPECTO FINAL | FINAL ASPECT

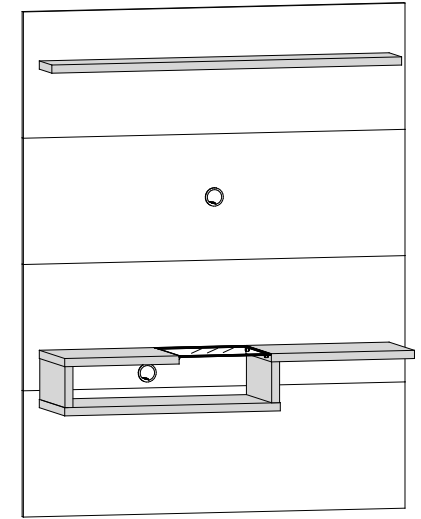

Espaço para Tv: → 1,200m ↑ 0,850m
Dimensão do Produto: → 1,200m ↑ 1,540m ↯ 0,330m

CUIDADOS ESPECIAIS

LIMPEZA: Pano limpo umedecido em água e sabão neutro
BRILHO: Flanela seca

SPECIAL CARES

CLEANING: Clean cloth humidified in water and neutral soap
SHINE: Dry flannel

CUIDADOS ESPECIALES

LIMPIEZA: Tela limpia humedecida en la agua y el jabón neutro
BRILLO: Franela seca

Edição: 07/01/2016

*Dimensões em metros | Dimensions in meters | Dimensiones en metros

REF.:	PEÇAS PIECE PIEZA	MATÉRIA PRIMA	DIMENSÕES* DIMENSIONS DIMENSIONES	QUANT.
202521	Panel inferior Bottom panel Panel inferior	MDP	1,200 x 0,385 x 0,015	1
202522	Panel central inferior Bottom panel Panel inferior	MDP	1,200 x 0,385 x 0,015	1
202523	Panel central superior Superior panel Panel superior	MDP	1,200 x 0,385 x 0,015	1
202524	Panel superior Superior panel Panel superior	MDP	1,200 x 0,385 x 0,015	1
202525	Travessa lateral Side line Lado do corril	MDP	1,200 x 0,060 x 0,015	2
202526	Apoio do painel Support panel Soporte del panel	MDP	0,960 x 0,081 x 0,015	1
202527	Apoio da parede Support wall Soporte del pared	MDP	0,900 x 0,058 x 0,015	1
202528	Base Base Base	MDP	0,678 x 0,298 x 0,025	1
202529	Tampo esquerdo Top left La parte superior izquierda	MDP	0,360 x 0,298 x 0,025	1
202530	Tampo direito Top right La parte superior derecha	MDP	0,450 x 0,298 x 0,025	1
202531	Lateral do nicho Side of the niche El lado del nicho	MDP	0,296 x 0,125 x 0,025	2
202532	Prateleira superior Upper shelf Estante superior	MDP	1,100 x 0,147 x 0,025	1
1.05.02.0046	Prateleira Shelf Estanteria	VIDRO	0,296 x 0,287 x 0,005	1

ACESSÓRIOS | ACCESSORIES | ACESORIOS

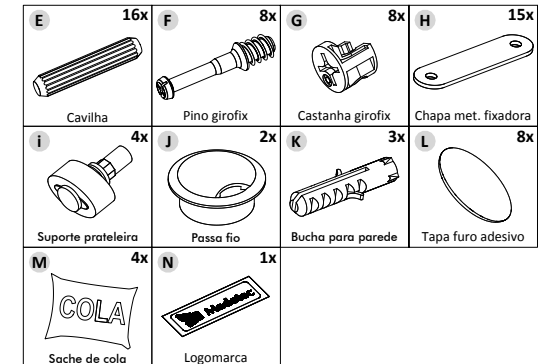
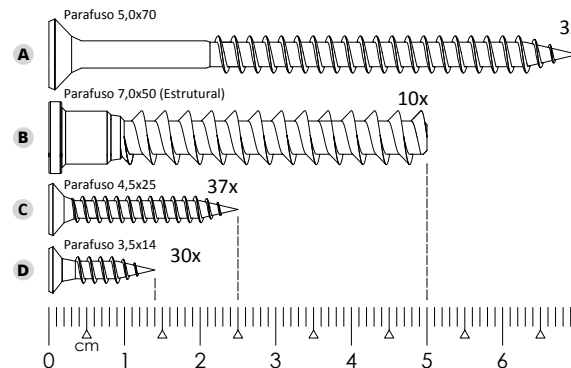

1º PASSO | PASS | PASO

PEÇAS
PIECES
PIEZAS

Obs.: passar cola na peça nº 202526 antes de encaixa-la no painel.

COLA

S.M.	C.P.
01	202524
02	202526
03	202523
04	202522
05	202521

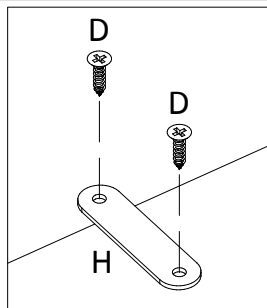
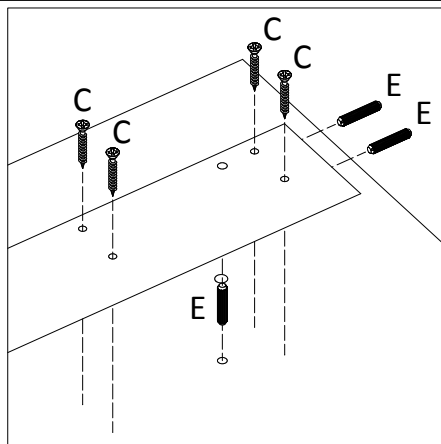
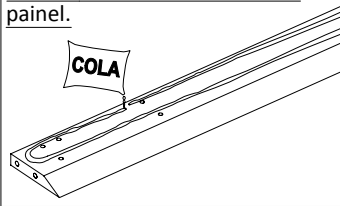

202526

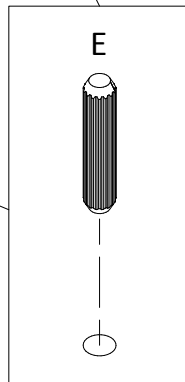
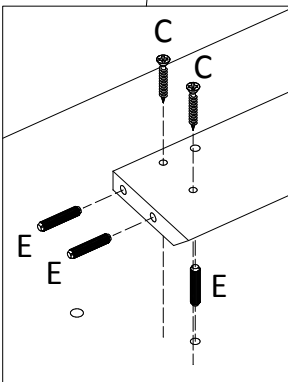
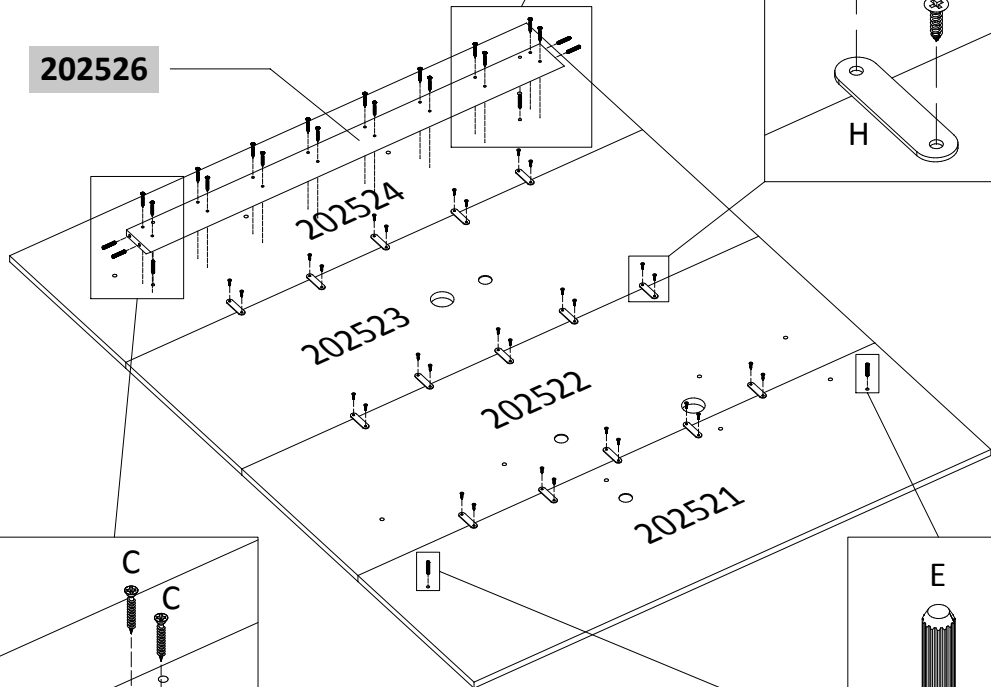

2º PASSO | PASS | PASO

PEÇAS
PIECES
PIEZAS

S.M.	C.P.
01	202525
02	202525

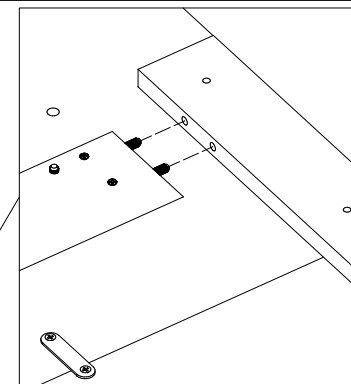

202526

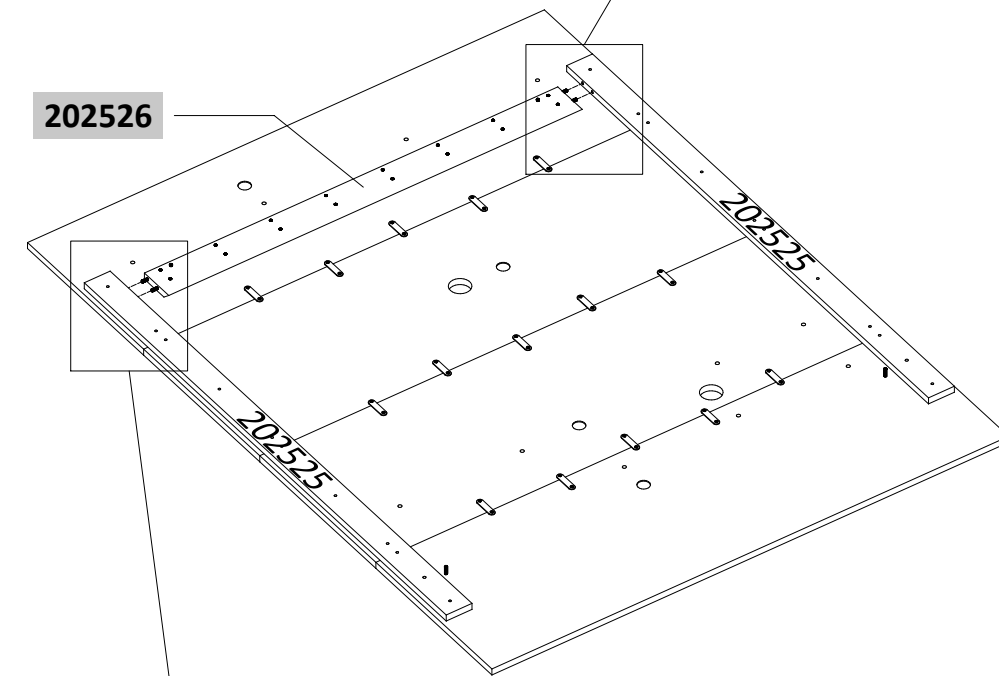

Obs.: passar cola em todas as travessas antes de encaixa-las nos painéis.

COLA

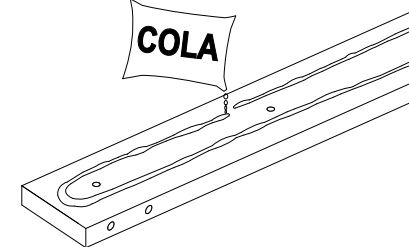

3º PASSO | PASS | PASO

Quebrar as sobras das cavilhas [E] conforme imagem.
Break the leftover of the bolts [E] according to the image.
Romper las sobras de los tornillos [E] conforme imagen.

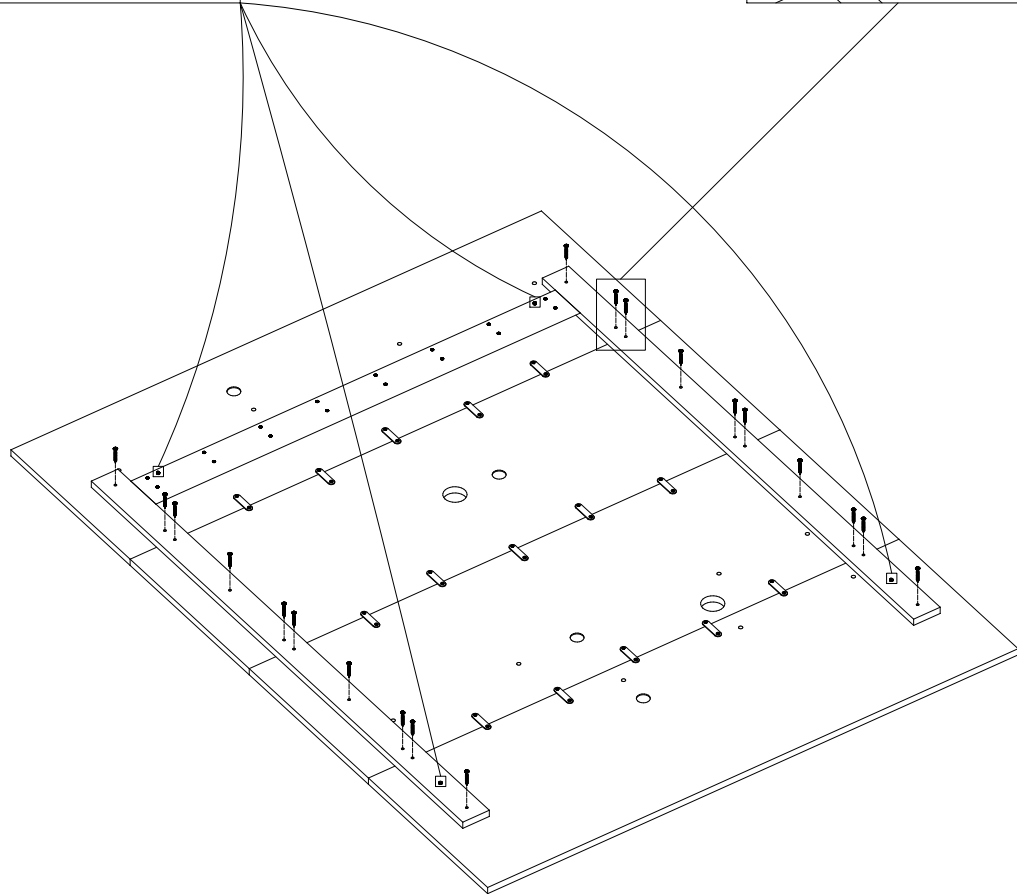
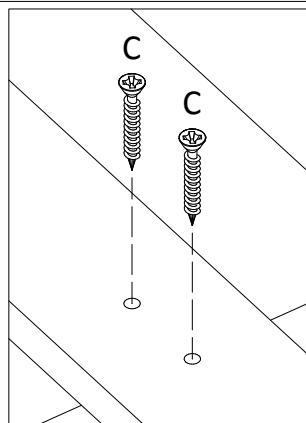
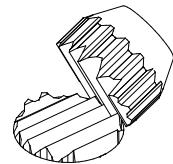

4º PASSO | PASS | PASO

PEÇAS
PIECES
PIEZAS

S.M.	C.P.
01	202528
02	202531
03	202531
04	202529
05	202530

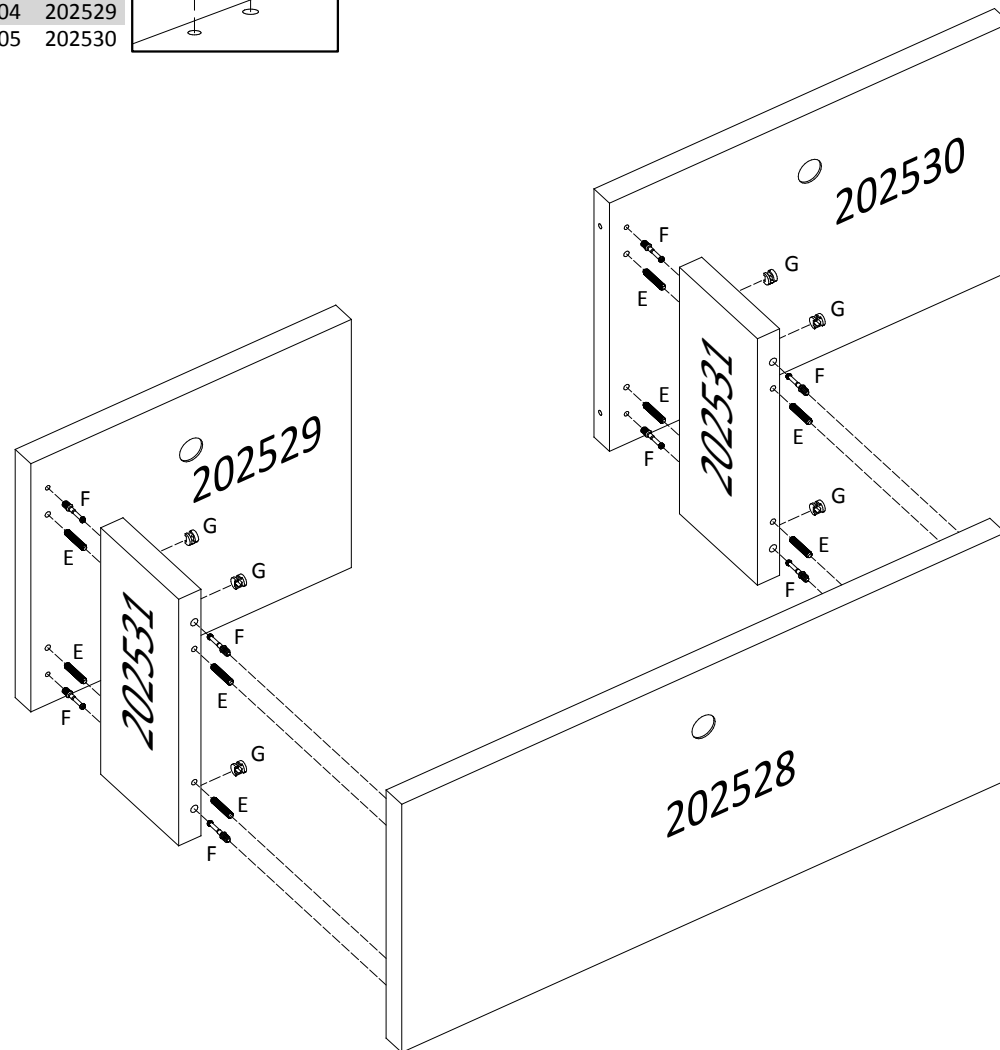
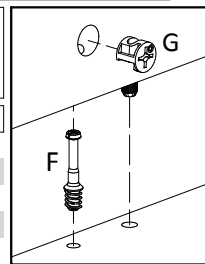

5º PASSO | PASS | PASO

PEÇAS
PIECES
PIEZAS

S.M. C.P.
01 202532

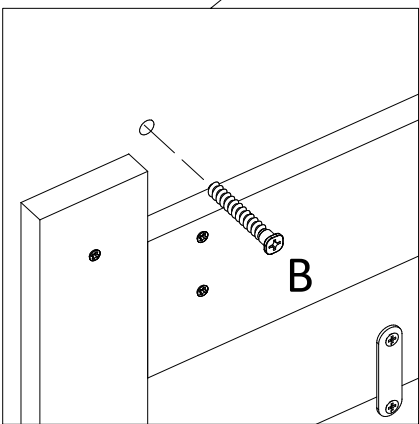
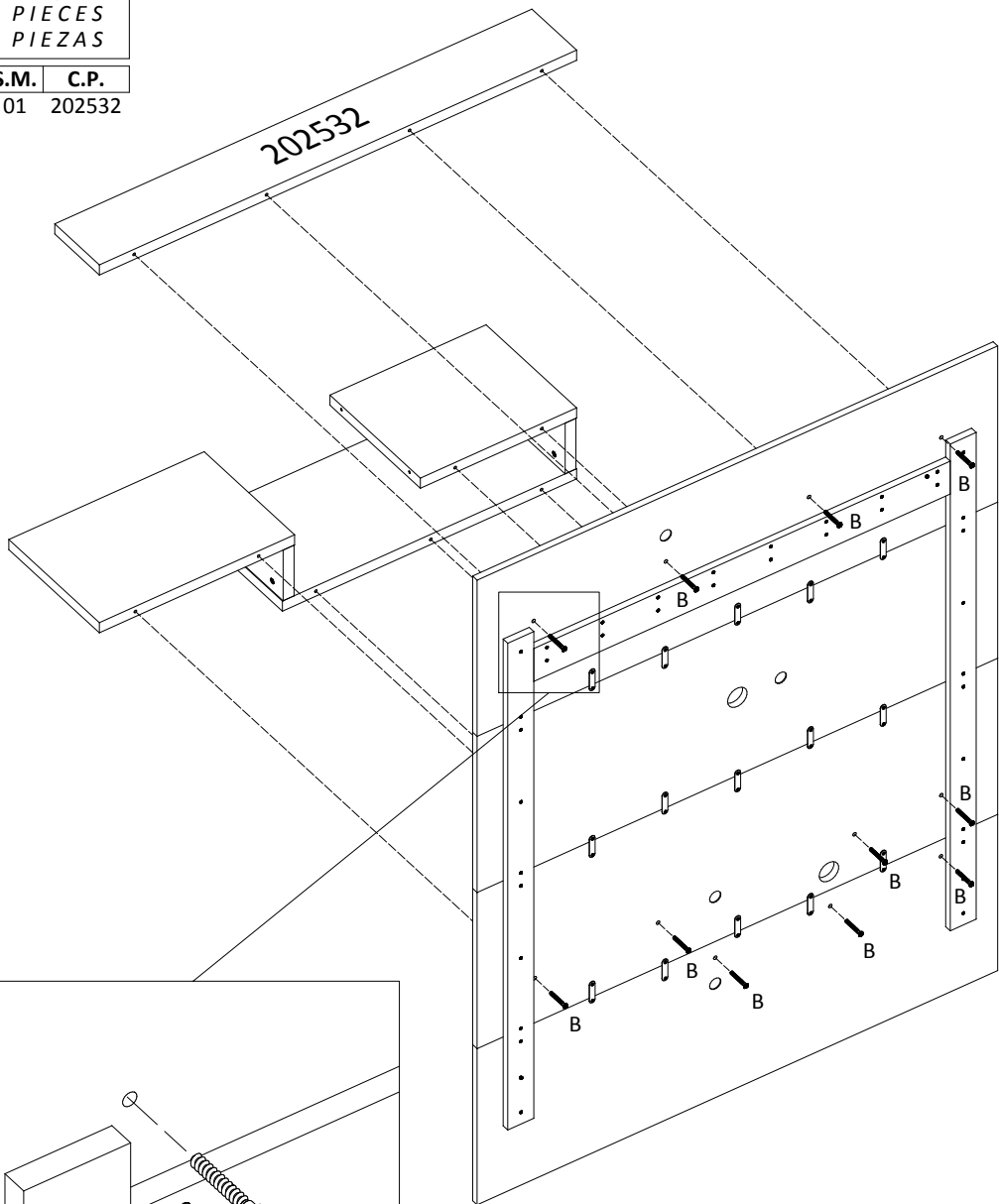

6º PASSO | PASS | PASO

PEÇAS
PIECES
PIEZAS

S.M. C.P.
01 202475

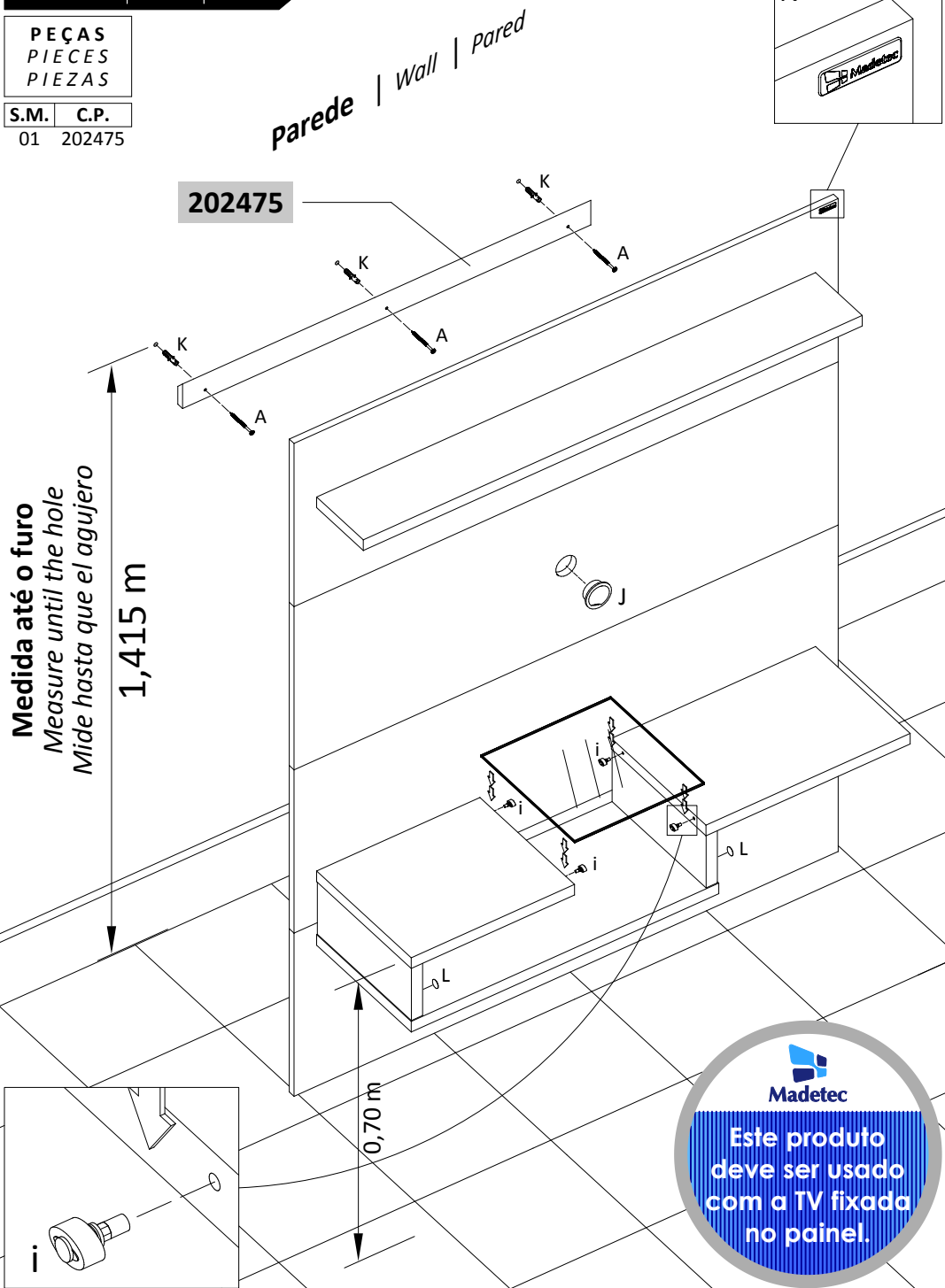

Medida até o furo
Measure until the hole
Mide hasta que el agujero

1,415 m

0,70 m



Este produto
deve ser usado
com a TV fixada
no painel.